

# Design of Water Quality Control for Shrimp Pond Using Sensor-Cloud Integration

Maman Somantri  
Department of Electrical Engineering  
Diponegoro University  
Semarang, Indonesia  
mmsomantri@live.undip.ac.id

Aghus Sofwan  
Department of Electrical Engineering  
Diponegoro University  
Semarang, Indonesia  
asofwan@elektro.undip.ac.id

M Arfan  
Department of Electrical Engineering  
Diponegoro University  
Semarang, Indonesia  
arfan@ft.undip.ac.id

Vivi Endar Herawati  
Department of Aquaculture, Faculty of  
Fisheries and Marine Science  
Diponegoro University  
Semarang, Indonesia  
viviendar23@gmail.com

Hafidhin Abdurrasyiid  
Department of Electrical Engineering  
Diponegoro University  
Semarang, Indonesia  
rasyidhaf@gmail.com

**Abstract**— Shrimp is one of the fishery export products that contribute greatly to the national fishery economy. Degradation of water quality of shrimp pond may cause problems in shrimp farming. Therefore, the water quality management system is proposed to provide the good quality water. The proposed system consists of water quality measurement monitoring system and aerator automation system based on timer. For a while, testing was carried out on 2 of 7 sensors there are PH and water temperature. The testing results of two sensors in the former system show the percentage of errors are small. And sensor data has been successfully sent to cloud server. Moreover, the test results of the latter system show the relay running well within the specified time.

**Keywords**—Monitoring system, Water Quality, Cloud

## I. INTRODUCTION

Efforts to improve the results of shrimp production as one of the commodities exports have been driven, by way of intensification of cultivation and extensive of potential land. Anticipating the development of shrimp farming in both intensively and extensively, has the same failed risk. One cause of the failures is poor quality of cultivation environment. Degradation of water quality of the shrimp pond induces problems such as many kinds of shrimp disease [1]. Since water is the main media so it needs more attention. Water quality also be one of the key factors of successful shrimp farming business. Water quality on shrimp farming easy to fluctuate, which is influenced by the activity of shrimp life itself or by the surrounding environment [2]. The shrimp activity influence can degrade water quality, thus leads to physiological disruption of shrimp. This is because the shrimp produces metabolism results in the form of urine dan dirt, and also contamination with the surrounding environment.

Two main category of parameters that are utilized to measure and determine the quality of water, i.e. physical and chemical categories. The former parameters are light intensity, water turbidity, water temperature and watercolor. And the latter parameters are dissolved oxygen (DO), free carbon dioxide (CO<sub>2</sub>), degree of acidity (pH), water hardness, alkalinity and salinity. In this research, four

physical parameters were taken, which are temperature, turbidity, color, and level of water, and three chemical parameters, which are acidity degree (pH), salinity and dissolved oxygen level (DO). Some recommended water quality specification there are temperature should be on 28<sup>o</sup> - 32<sup>o</sup>C, PH optimal on 7.5 – 8, dissolve oxygen optimal on greater than 4 ppm, salinity optimal on 15 – 25 ppt [3].

Water quality control is carried out by running an aerator at a certain time to create aeration and monitor water conditions with certain parameters. Aeration is the process of increasing the oxygen content in the water environment, with the aim of making living organisms in it grow healthier and faster. Based on field surveys, the applied water quality control system is still using manual technique by taking water samples at a certain time. The water is measured using tools, and then the measurement results are recorded into the report file. And also, operation of the aerator performs manual technique, the farmer turn on and turn off the aerator manually on certain times. By controlling water quality automatically will make it easier for farmers to manage water quality condition effectively and efficiently. Furthermore, monitoring of water quality condition data through web-based internet network makes it easy for farmers to monitor from a distance at anytime and anywhere. Therefore, monitoring and improving the quality of aquaculture water needs to be done, so that the water quality control management is designed using sensor-cloud integration, in order to provide a good quality water.

The structure in this paper is arranged as follows. We describe the methodology of quality control management of shrimp in detail on the Section II. The results of designed system on the Section III. And then followed by conclusion in the last section

## II. METHODOLOGY

In this section, we describe the methodology that is applied in our research. The cloud computing, tools and material, measurement method of sensor, method of sending data to the cloud, water quality measurement monitoring, and aerator automation system are exposed in detail.

### A. Cloud Computing

Cloud computing works by using a server that is continuously online on the internet network. On this server computer, all data will be stored as well as the application,

so the user is ready to use it. Users who want to access the server either for opening, storing data or running a program. Mobile Cloud Computing is a mobile device application development to develop management data capacity from distributed data by adding benefits. Another definition of mobile cloud computing is cellular computing technology using integrated device and network resources so that high mobility and limited storage will meet a cellular cloud system that can serve many mobile devices anytime, anywhere up to the Internet. Smart phones, tablets and similar device are part of a cloud-based three resources group which are cellular computing entities [4]. The relationship between Sensors and Cloud Computing is created because of the integration of sensors into the public network (internet) based on Cloud Computing technology, so that it can accommodate better computing capabilities, it is also able to provide more reliable storage media for all data scanned by the sensor. Fig. 1 illustrates the Sensor cloud integration architecture.

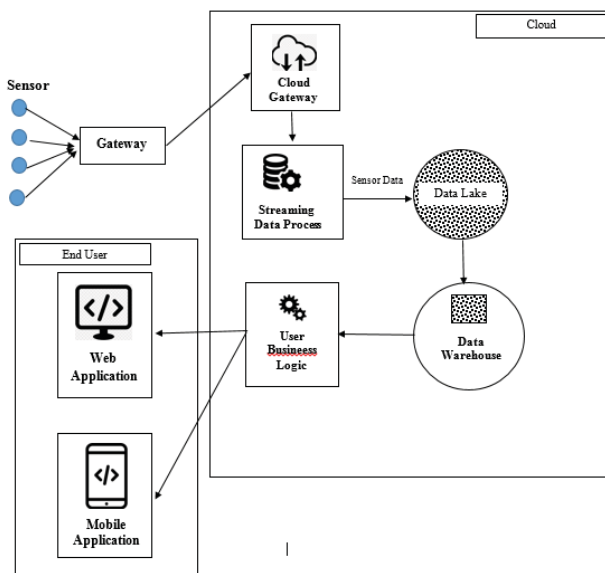

Fig. 1. Sensor cloud integration architecture

### B. Tools and Materials

Tools and materials used in this research were Arduino IDE version 1.8.0 to insert embedded functions through programming syntax on arduino microcontroller, PHP 4.5, Javascript, and HTML tag to build a website, use Mysql for database management system [5], also some component to build hardware device were Arduino Mega 2560 as main controller, relays to control an aerator, LCD 16x2 to display aerator status, RTC DS3231 to give time input and some water measurement sensor were PH, water temperature, dissolve oxygen, salinity, turbidity, water level sensor, and watercolor sensor.

### C. Measurement Method of Sensor

Sensors are devices for detecting/measuring something that is used to alter mechanical variations, magnetic, heat, light, and chemical into voltage and electric current. Sensor consists of a transducer with or without the signal amplifier/processor formed in a single sensing system. In this research, the system uses 7 sensors there are PH, water temperature, dissolve oxygen, salinity, turbidity, water level

sensor and watercolor sensor. Explanation of each working principle of the sensor as follows.

- PH sensors, pH measurements are based on the electrochemical potential that occurs between the solutions contained in the glass electrode (membrane glass) known to the solution found outside the unknown glass electrode. because the glass bubble layer will interact with hydrogen ions, the electrochemical potential of hydrogen ions will be measured using a glass electrode. To complete the electrical circuit, a comparable electrode is needed. The sensor does not measure the current but only measures voltage. if the water is more alkaline then the sensor produces a smaller voltage if more water then the sensor produces a greater voltage.
- Dissolve Oxygen (DO) sensor, also called oxygen demand, is one of the important parameters in water quality analysis. The DO value is a measure of the amount of oxygen dissolved in water, measured in units of mg / L or ppm. The working principle of this DO meter sensor is using electrode system where the oxygen content reacts with the cathode to produce an electric current [6]. Membrane electrode method has 2 type, there are Polarographic method and Galvanic cell method. The method used in this research is Galvanic cell. The membrane has a high permeability to oxygen so that the electrolytes and electrodes are isolated from the measured water. Functioning electrodes are precious metals. Counter electrodes are base metals. which functions as an electrolyte is potassium hydroxide. The membrane is passed by Oxygen and the working electrode is drops, so this method measures the reduction current that flowing between two electrodes, which is proportional to the dissolved oxygen concentration.

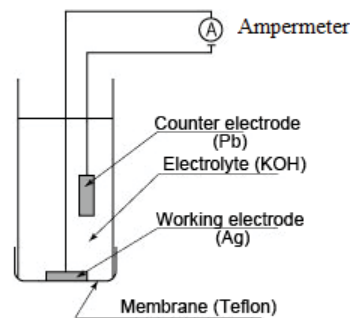

Fig. 2. Dissolve oxygen sensor with Galvanic Cell membrane electrode method

- Salinity sensor, uses two electrodes that serve to inject the current into the water. The current flows through the water, where in this case the brine is a strong electrolyte solution that can conduct an electric current. The electric current flowing is proportional to the conductivity of the brine. This means that if the salinity value is high, then the conductivity value is also high. The electric current flowing in water, is inversely proportional to the resistance value of the brine. The higher the conductivity then the resistance value is getting smaller.
- Water temperature sensor, DS18B20 is one type of temperature sensor. The temperature sensor resolution is

9 - 12 bits, with the increments of 0.5°C, 0.25°C, 0.125°C, and 0.0625°C, respectively. The master must issue the Conversion T command [44h] to start temperature measurement and A-to-D conversion. After conversion, the generated thermal data is stored in a 2-byte temperature register in the scratchpad and DS18B20 memory back to rest. And then DS18B20 will respond by transmitting 0 when the temperature conversion is in progress and 1 when the conversion is complete.

- Turbidity sensor, water flows between two projections of transparent plastic. This projection is done by phototransistor and photodiode respectively. The phototransistor emits a beam of light until it reaches the photodiode. These light rays are formed and will lose their path when they meet particles suspended in the water. As a result, the light received at the photodiode is less amplitude when compared to when it is emitted. The value of the sensor is taken from the comparison.
- Water level sensor, used to measure water level using ultrasonic sensors. In ultrasonic sensors, piezoelectric produces ultrasonic waves by generating frequency. Ultrasonic waves will be produced by this Piezoelectric. These sensors emit ultrasonic waves to an area or target. and after that the wave will be reflected back. The sensor will capture the reflected wave from the target, then the difference between the delivery time and the received time will be calculated by the sensor. According to the datasheet this sensor has a maximum measuring distance of 400 cm. Figure 3 illustrates the working principle of ultrasonic sensors.

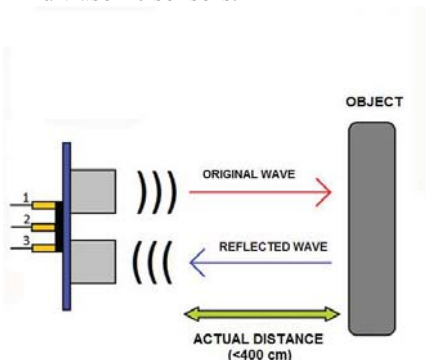

Fig. 3. Ultrasonic sensor working principle

- The water color sensor, The TCS3200-DB color sensor is a type of color detector. Consist of a TCS3200 RGB TAOS sensor chip, a white LED, a collimator lens, and a deadlock to adjust the optimal sensing distance. TCS3200 has an array of photodetectors, each with red, green, or blue filters, or without filters (obviously).

#### D. Method of Sending Data to The Cloud

In this research, we applied Hypertext Transfer Protocol (HTTP) protocol. This feature is available on ESP8266 module. The response request protocol between client and server is HTTP [7]. HTTP messages are requests or responses. The server listens for connections to requests, parses each received message, interprets semantic messages in relation to identified target requests, and responds to

those requests with one or more response messages. A request message to communicate a specific purpose is built by the client, checks the response received, and determines how to interpret the results. Applications on computers that host websites as a servers and web browsers as a clients. Two commonly used methods for requests between clients and servers are: GET and POST. In this research, the GET method is used to send data to the server.

#### E. Water Quality Measurement Monitoring System

Design of water quality measurement monitoring system required some components such as some sensor related measurement parameters such as temperature, PH, Dissolve Oxygen, salinity, turbidity and watercolor, water level. Then the controller component is Arduino board with Mega 2560 version. It is a microcontroller board from Arduino with the ATmega2560 chip [8]. This board has a lot of input/output pins there are 54 digital input/output pins and 16 analog inputs. In this research design Arduino Mega is equipped with ESP8266 module. It is an integrated chip component designed for cloud computing concept. The ESP8266 has storage capabilities and onboard processing that enable the chip to be integrated with sensors or with specific device applications via input-output pins and through serial interconnects (UART RX / TX) as access into the network [9]. Fig. 4 illustrates the main design of water quality measurement monitoring system used in this research.

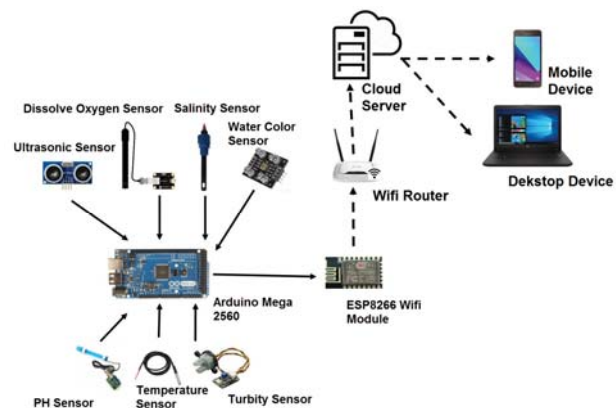

Fig. 4. Water Quality Measurement Monitoring System Design

Arduino Mega 2560 will process each input value of the sensor in the form of analog value, then the input is converted into digital value. Arduino Mega 2560 has 15 analog pins and in this research using 7 analog pins for sensor. The sensor values will be sent to server via the ESP8266 module. Sensor value is sent to the server through the HTTP protocol with HTTP request GET. The server side has prepared files to save every sensor value into database. Furthermore, framework CodeIgniter is used to build a website [10]. The framework provides are many features, e.g., segment feature, which is utilized in this research.

#### F. Aerator Automation System

Fig. 5 exposes the design of aerator automation system. Arduino Mega 2560 will process a timer that has been set with some specified time. The component for controlling the timer is DS3231 RTC. Microcontroller will initialize particular time to control the relay. Relay control results and the time are displayed on the 16x2 LCD for provide the real-

time information and the relay status. The relay will work according to the biner logic 1 or 0 given by the microcontroller based on the timer. The current cable in the aerator is connected to the common pin and normally open on the relay. Then the current cable and ground on the aerator are connected to the AC current voltage. So that the activity of turn on and turn off from the aerator is based on the logic provided by the relay. If the LCD displays the time according to the conditions that have been set. The microcontroller will give the logic 1 to the relay and the relay will be active and the aerator will also turn on.

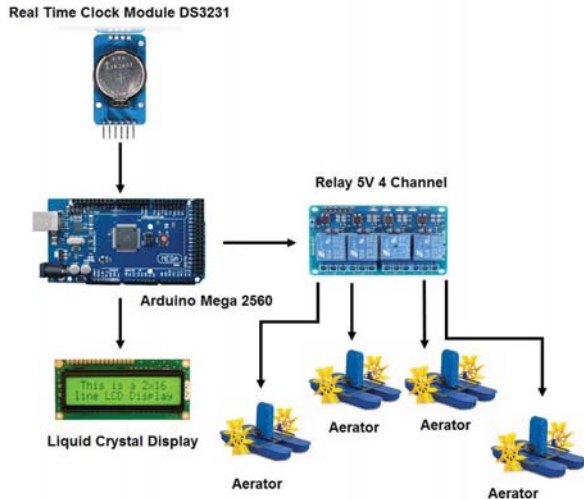

Fig. 5. Aerator Automation System Design

### III. RESULT

In this research, we perform testing into two systems, which are water quality monitoring and aerator automation system. Validation test on the former system is conducted in order to obtain the percentage of measurement sensors error. Currently, we perform testing in two sensors, which PH and temperature sensors. While the validation test on the latter is performed to determine the success of control relay work based on the time has been set.

#### A. Water Quality Monitoring System Validation Test

We perform two scenarios of testing, which are testing for PH sensor and temperature sensor. For the former test, we conduct validation test for the water quality monitoring system by entering probes of PH sensor and PH meter into solvent PH buffer. Fig 6 shows the comparison of PH measurement results of the both probes in the PH buffer. From the figure we obtain implicitly the error percentage of the measurement with value of 0.3%, 0.23%, 0.23% for normal pH, acidic, alkaline environments, respectively. Therefore, we conclude that the PH sensor has been working properly because PH sensor has small measurement error.

Furthermore, the PH sensor data result sent to server by taking 23 times data test, which are displayed on website, as shown in Fig.7. From the figure we claim that PH sensor data has been successfully sent to server. In addition, the website can display and report PH value from database in cloud to client browser.

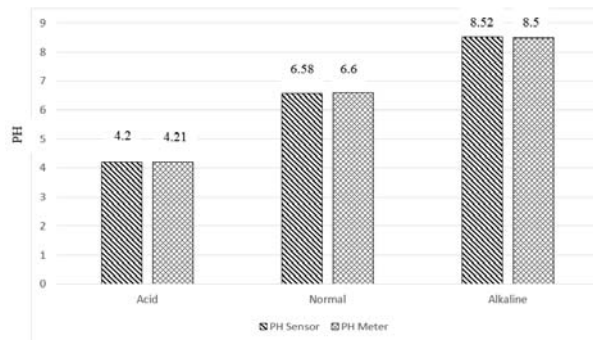

Fig. 6. Comparison of PH Measurement

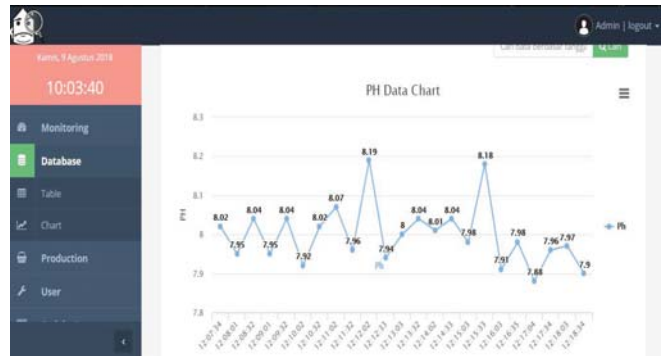

Fig. 7. Display PH sensor measurement on the interface

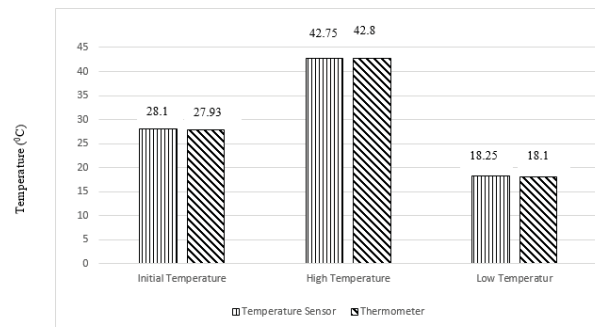

Fig. 8. Difference of Temperature Measurement



Fig. 9. Difference of Temperature Measurement

The latter scenario is inserting the temperature sensor probe and the water thermometer in water at initial temperature, high temperature, and low temperature conditions, as shown in Fig. 8. From the figure we obtain implicitly percentage of measurement error with value of 0.6%, 0.11%, 0.8% on the initial temperature, high temperature,

and low temperature conditions, severally. Therefore, we conclude the temperature sensor of the monitoring system has been working properly because the water temperature sensor shows a small measurement error

The results of the temperature sensor data sent to server by taking data test for 23 times, as shown in Fig. 9. From the figure we conclude that the temperature sensor data has been successfully delivered to server. Moreover, the website can show and report temperature value from database in cloud to browser.

### B. Aerator Automation Validation Test

The scenario of aerator automation test is performed to observe the success of the relay control system with specified time parameters. Based on field surveys, the timer is divided into 2 sessions time, morning session and afternoon session, morning session at 08.00 relay activated for 4 hours then afternoon session at 14.00 relay activated for 4 hours.

TABLE I. RELAY TEST RESULT

Time	Test Results			
	Relay 1	Relay 2	Relay 3	Relay 4
08.00	ON	ON	OFF	OFF
12.00	OFF	OFF	OFF	OFF
14.00	OFF	OFF	ON	ON
18.00	OFF	OFF	OFF	OFF

Based on Table I, we indicate the system has been running well based on specified time. Relay conditions have been in accordance with the time specified. Relays 1 and 2 are active when the LCD display shows at 08.00 and deactivate exactly 4 hours later at 12.00, and relays 3 and 4 was active at 14.00 and deactivate exactly 4 hours later at 18.00.

## IV. CONCLUSION

In this paper, we expose the design of water quality control for shrimp pond using sensor-cloud integration. The designed system consists of water quality monitoring and aerator automation system. The validation test of the both

systems shows they have been working properly with small error values in various conditions. And also the results of digital data from processing the analog value of sensors processed by the microcontroller, have been successful and the digital value of the sensor has been successfully sent to the cloud server then the website has been successfully accessed by the client. So, farmers are able to easily monitor water conditions anywhere. And the system has successfully controlled relays that are integrated with aerators automatically in an effort to create aeration to maintain and improve water quality.

## ACKNOWLEDGMENT

This research was supported by Superior Research of Higher Education (*PUPT*) – Diponegoro University grant in the fiscal year 2018.

## REFERENCES

- [1] A. Sahrijanna and S. Sahabuddin, "Water Quality Study on Vannamei Shrimp cultivation (*Litopenaeus Vannamei*) With Food Experience System in Intensive Ponds," *Proc. acquisitive Technol. Innov. forum*, pp. 313–320, Dec. 2014.
- [2] B. C. Das, M. K. Begum, M. A. Masud, M. Z. Rahman, and K. Mazhabuddin, "Socio- economic condition of the fish and prawn gher farmers at Dakatia Beel in Khulna, Bangladesh.," *J. Environ. Sci. Nat. Resour.*, vol. 7, no. 2, pp. 163–168, 2014.
- [3] D. Wiyatno, N. Sasono, A. Tantowi, and Barudin, "Cultivation of Vaname Shrimp," p. 134, 2013.
- [4] M. Arfan and A. M. C. Computing, "Mobile Cloud Computing Security Using Cryptographic Hash Function Algorithm," 2014.
- [5] A. Sofwan *et al.*, "Implementation of Vehicle Traffic Analysis Using Background Subtraction in The Internet of Things (IoT) Architecture," *6th Int. Conf. Inf. Commun. Technol.*, pp. 24–27, 2018.
- [6] B. H. Tirtowidiyadi, "Integral Plus Proportional Control App On Oxygen Levels Setting (Dissolved Oxygen)," Final Project Paper, pp. 1–8, 2006.
- [7] S. K. Rajinder Singh, "An Overview of World Wide Web Protocol (Hypertext Transfer Protocol and Hypertext Transfer Protocol Secure)," *Int. J. Adv. Res. Comput. Sci. Softw. Eng.*, vol. 3, no. 2, pp. 251–259, 2013.
- [8] S. E. Agung, *Arduino Programming Smart Book*. Yogyakarta: Mediakom, 2015.
- [9] M. Wicaksono and Hidayat, *Easy Learning Arduino Microcontroller*. Bandung: Informatika, 2017.
- [10] A. K. Himawan, "Performance Analysis Framework Codeigniter and CakePHP in Website Creation," vol. 94, no. 20, p. 8887, 2014.