

Comparison Power Consumption 125 Watts Pump by Using AC and DC Based on Solar Energy

S. Sulisty
Mechanical Engineering Department
Engineering Faculty Diponegoro
University
Semarang, Indonesia
National Center for Sustainable
Transportation Technology
Indonesia
listyotm@ft.undip.ac.id

Ade Mukti Wibowo
Mechanical Engineering Department
Engineering Faculty Diponegoro
University
Semarang, Indonesia)
ade.mukti24@gmail.com

Sri Nugroho
Mechanical Engineering Department
Engineering Faculty Diponegoro
University
Semarang, Indonesia
srin.sroy@gmail.com

Abstract— The development of photovoltaic has shown the maturity of technology. The application can already be used as a source of electrical energy and is an environmentally friendly source of electrical energy. The use of PV technology in Indonesia has developed well for the generation of electricity for companies or household units as an alternative energy source. Currently, Indonesia has begun to develop electric car transportation by using batteries, so that it was need inverter equipment which change a direct current to the alternating current. This paper discusses the comparison of power consumption 125 watts pump by using alternating current (AC) and direct current (DC) based on solar energy using photovoltaic (PV). The type PV cell uses a 100-watt peak solar cell type silicon mounted on a portable basis and parallel connected. The PV is installed at Semarang region which connected by battery. The type battery is 100 AH, 12 V. The battery was connected to motor pump of 125 watts. There are two motors type which has specification as DC motor and AC motor. The DC motor should be connected by DC-DC converter before DC motor pump to increase the requirement voltage of motor pump while AC motor should be provided by inverter DC to AC. The pump was connected by piping system which suction pipe use a diameter of 32 mm and discharge pipe of 20 mm. The total head for both experiment is 4 m. The speed of motor was measured as in motor specification. The operating of PV was at 08.00 am – 16.00 pm. The result of the power consumption of the DC motor was more efficiency than by using AC motor. The operation of the battery using DC motor is about two times longer than AC motor.

Keywords—*photovoltaic, power consumption, DC motor*

I. INTRODUCTION

The development of photovoltaic has shown the maturity of technology. The application can already be used as a source of electrical energy and is an environmentally friendly source of electrical energy [1]. The use of PV technology in Indonesia has developed well for the generation of electricity for companies or household units as an alternative energy source [2,3,4]. Currently Indonesia must be prepared the diversification of cleaned energy to reduce the Green house effect [4]. There are several type of clean energy include nuclear energy [5], wind energy, energy of water fall, hydrogen energy and solar power. Hydrogen energy was converted into electricity by using fuel cell [6] while solar power was into electricity through photovoltaic cell [1]. Photovoltaic cell converted solar energy into electricity of direct current which has relatively

low voltage each of panel. The equipment should be installed series or parallel to produce the certain voltage. Usually photovoltaic system was equipped with battery as storage energy due to the sun power was available in half day while the electricity should be one day operation full. Fig. 1 show the schematic diagram of the photovoltaic (PV) which was conneted by battery as power electric generation [7].

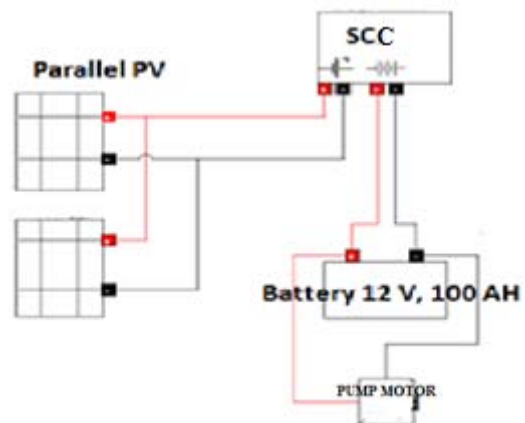

Fig. 1. Schematic diagram of photovoltaic (PV)[7]

Schematic diagram as in Fig. 1 consist of two panels PV, solar charger controller (SCC), battery and pump motor as load. The function of the panels PV is to convert solar energy into electric direct current, SCC is to control the current enter to the battery and battery is as storage electric energy. This paper discussed the comparison power consumption 125 watts pump by using AC and DC based on solar energy. The discussion is about using panel PV which intalled in Semarang region, Central Java Indonesia. The altitude of Semarang city is around 0 – 350 m above sea level.

II. METHOD AND EQUIPMENT

The specification of the photovoltaic (PV) as follows:

TABLE I. PV SPECIFICATION

No	Type	Note
1	Photovoltaic	Monocrystalline silicon

2	Maximum Power	100 W
3	Voltage at Pmax	18.1 V
4	Current at Pmax	5.5 A
5	Open-circuit voltage	22.2 V
6	Short circuit current (Isc)	6.00 A
7	Dimension surface	1020x670 mm ²
8	Operating temperature	45-80 C

The auxiliary equipment includes solar charge controller (SCC), Battery Valve Regulated Acid (VRLA) 100 AH, 12 V. Digital multimeter, Thermohygrometer, DC clamp meter, Irradiance meter. SCC is used to control the current entering the battery and the power supply breaker from PV when it was full. It can arrange the current and voltage to battery so it can protect the damage and improve the life of battery. The inverter direct current (DC) to alternating current (AC). It used to convert DC to AC which has voltage output around 220 V as it needs for pump motor. The booster DC to DC which used to increase DC voltage until DC pump motor running as motor specification around 48 V while battery output is 12 V. The voltage from battery must increase to achieve the motor rotation of 3000 rotation per minutes (RPM). Two motor pumps are used to drive the pump which was evaluated the power consumption. The pump specification is 22 liters perminutes output and the total head of 43 meters. The AC motors 220 V, 300 watts input and output 125 watts, 3000 RPM. The DC motor input 125 watts, 12-48 V, 3000 RPM The specifications of rature surrounding PV. Irradiance meter was used to measure the sun radiance that hit the PV. Fig. 2. shows the diagram of circuit PV which was connected by electric DC motor pump. The circuit consist of the PV panel, SCC, Battery 100 AH, 12 V, booster DC to DC, and DC motor pump as load.

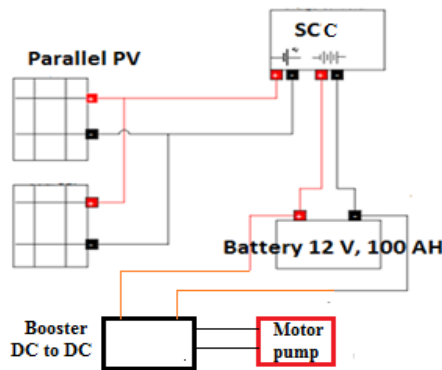

Fig. 2. The circuit PV which connected by DC motor pump.

III. RESULT AND DISCUSSION

The result of intensity measurement of sunshine and current from PV are presented in the table as follow. TABLE I shows the intensity from time 08.00 until 16.00. The PV was intalled by a parallel panel at Semarang. The altitude of the Marina Beach is around 7.5 m - 450 m above sea level.

TABLE II. Intensity and current of parallel PV at Semarang

time	Intencity light sun (W/m ²)	Temp. PV (°C)	Ambient temperature (°C)	Humidity (%)	Panel to SCC			SCC to battery		
					voltage (V)	current (A)	Electric energy (Wh)	voltage (V)	current (A)	Electric energy (Wh)
08.00	525,7	47,5	34,8	57%	12,4	6,5	80,3	12,3	6,4	78,4
09.00	777,0	47,6	34,7	55%	12,7	7,1	89,8	12,6	7,0	87,9
10.00	944,5	43,9	34,0	55%	12,8	9,3	119,0	12,7	9,2	116,6
11.00	830,5	47,9	35,7	56%	13,2	9,1	119,7	13,0	9,0	116,8
12.00	765,8	47,5	38,3	57%	13,3	8,7	114,8	13,1	8,6	111,9
13.00	609,8	44,4	37,5	59%	13,3	7,8	103,3	13,2	7,7	100,7
14.00	439,5	38,9	36,3	60%	13,3	6,3	83,7	13,2	6,2	81,7
15.00	276,5	34,5	34,8	60%	13,2	3,5	45,7	13,1	3,4	44,6
16.00	288,0	35,2	33,8	63%	13,1	1,9	24,9	13,1	1,8	23,5

TABLE II show at time of 08.00 the intensity of light sun 525.7 W/m², temperature of panel 47.5 C, ambient temperature of 34.8 C, humidity of 57 %, panel PV produce voltage of 12.4 V, curent of 6.5 A. It is equal power of 80.3 W, while measurement voltage and current from SCC to battery are 12.3 V and 6.4 A respectively. It is equal power of 78.4 W. The power from panel to battery decline due to power change into heat through wire in the SCC and external wire [8]. The maximum of sun intensity is at 10.00 o'clock, it produces sun intensity of 944.5 W/m² and the energy enter in the battery of 116.6 Wh. The energy enter is still high at 11.00 o'clock about 116.9 Wh due to the temperature of the panel at 11.00 is higher than at 10.00. Thus the temperature of the panel also affect the energy supply to battery [1]. The application of energy battery as long as operation AC pump motor is in TABLE II. The battery is not connected with PV panel

TABLE II ENERGY OPERATION USING AC MOTOR PUMP

Time	SOC (%)	DOD (%)	Battery to Inverter			Inverter to pump motor			Energi battery (Wh)	Note
			voltage (V)	current (A)	power (W)	current (A)	voltage (V)	power (W)		
start	100%	0%	12,9	-	-	-	220	-	1200	No Load
16.00	69%	31%	12,31	20,2	248,7	1,1	220	242	799,7	Starting
17.00	41%	59%	11,89	22,8	271,1	1,2	218	255,1	528,6	
18.00	21%	79%	11,51	23,4	269,3	1,2	219	258,4	259,3	
19.00	0%	100%	10,29	25,2	259,3	1,1	220	246,4	0	End

TABLE II shows the capacity battery without connected by PV panel. At start time the energy battery drop about 31 % of the capacity battery. Total energy battery 100 AH, 12 V is 1200 Wh. The energy was taken by AC motor pump to overcome the friction in the part of the motor itself and heat losses in the wire motor [8]. The available energy battery is about 69 % or about 799.7 Wh. After operation one hour the energy battery is 528.6 Wh. The battery operation can achieve about three hours. The operation of battery use DC motor can be seen in the TABLE III.

TABLE III shows the energy battery without connected by PV panel. The operation start at 16.00 o'clock. The starting energy operation is about 26 % . It is less than using AC motor pump. At 16.00 energy in the battery is available about 880 Wh. After one hour pum operation energy battery is still 744.06 Wh or 62 % total battery capacity. The operation of battery can achieve 6 hour operation. The using of DC motor can reduce energy operation than using AC motor. The comparison of operation DC motor and AC

motor pump without connected by PV panel can be seen in the Fig. 3

TABLE III ENERGY BATTERY USING DC MOTOR PUMP

Time	SOC (%)	DOD (%)	Battery to pump motor DC			Energy battery (Wh)	Note
			current (A)	voltage (V)	power (W)		
Start	100%	0%	-	38,9	-	1200	No Load
16.00	74%	26%	3,3	38,5	127,05	880	Starting
17.00	62%	38%	3,54	38,4	135,936	744,064	
18.00	51%	49%	3,54	38,4	135,936	608,128	
19.00	40%	60%	3,45	38,4	132,48	475,648	
20.00	30%	70%	3,41	38,4	130,944	344,704	
21.00	18%	82%	3,41	38,4	130,944	213,76	
22.00	7%	93%	3,36	38,4	129,024	84,736	End

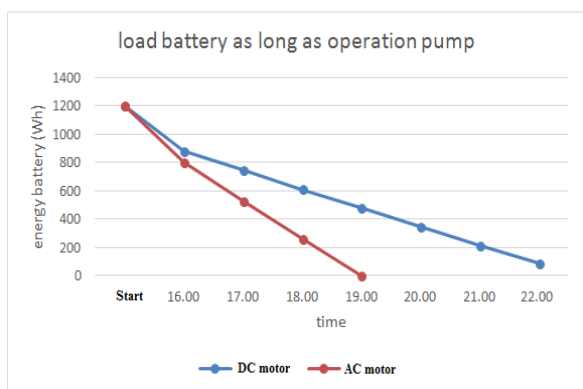

Fig. 3 Comparison battery operation using AC dan DC motor pump without PV panel

Fig. 3 show the comparison of operation battery using AC and DC motor pump without connected by PV panel. The energy operation battery using DC motor pump can reduce application electric consumption of energy battery. The Fig. 3 show the operation of DC motor can operate until 6 hour operation while the AC motor pump is only three hours. Fig. 4 shows the energy consumption of AC and DC motor pump which connected by parallel PV panel.

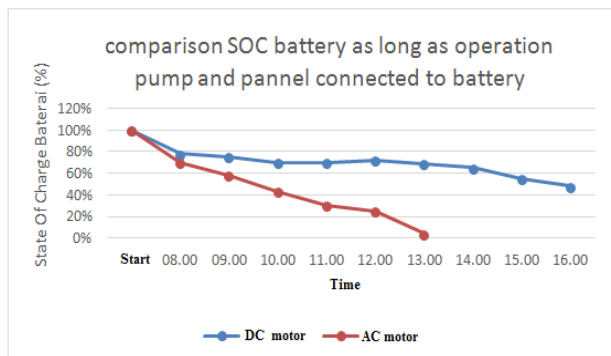

Fig. 4. Comparison SOF battery which conneted by AC and DC motor pump and parallel PV panel

Fig. 4 show the comparison of SOC (state of charged) battery using AC and DC motor which connected by parallel

PV panel. The operation battery using DC motor pump is longer than AC motor pump. The operation battery can achieve 8 hours and in the battery is available about 42 % SOC, while the AC motor pump is only the operation of 5 hours and available energy battery is 0 %. It real that the DC motor pump can save the operation of the energy. The AC motor is no saving energy due to the losses of the wire into heat and fricton of the part element of the motor [1,8].

IV. CONCLUSION

Several conclusion can be taken as following

1. The charging of parallel panel can be maximize at around 10.00 – 11.00 o'clock. The maximum energy battery at 11.00 is higher than at 10.00 although the intencity sun shine is lower than at 10.00 o'clock. It is caused by the surface panel temperature at 11.00 is higher than at 10.0 o'clock
2. The using of DC motor pump can reduce the application of energy battery.
3. The energy battery of DC motor pump which connected by using parallel two panels can increased the life charging battery and reduce the energy consumption.

V. ACKNOWLEDGMENT

This paper was supported by Mechanical Engineering Department Diponegoro University and USAID through Sustainable Higher Education Research Alliance (SHERA) Program – Center for Collaborative (CCR) National Center for Sustainable Transportation Technology.

VI. REFERENCE

- [1] A. A. Elbaset and M. S. Hassan, *Design and Power Quality Improvement of Photovoltaic Power System*. 2017.
- [2] M. Retnanestri, H. Outhred, and S. Healy, "Off-Grid Photovoltaic Applications in Indonesia: A Framework for Analysis," no. October, 2011.
- [3] R. A. Messenger and J. Ventre, *Photovoltaic systems engineering*. 2004.
- [4] anonyms, *Global EV Outlook 2017: Two million and counting*. 2017.
- [5] S. Suman, "Review Hybrid Nuclear-Renewable Energy System: A review," *J. Clean. Prod.*, vol. 181, pp. 166–177, 2018.
- [6] K. C. Wincewicz and J. S. Cooper, "Taxonomies of SOFC material and manufacturing alternatives," vol. 140, no. August 2004, pp. 280–296, 2005.
- [7] S. Sulisty, "Charging Quality of 100 Amper-hours Battery Using a Silicon Photovoltaic at Different Altitude in Semarang Region," *2018 5th Int. Conf. Electr. Veh. Technol.*, pp. 100–102, 2018.
- [8] C. E. L. Latunussa, F. Ardeno, G. A. Blengini, and L. Mancini, "Life Cycle Assessment of an innovative recycling process for crystalline silicon photovoltaic panels," *Sol. Energy Mater. Sol. Cells*, vol. 156, pp. 101–111, 2016.