

Integration of the Stimulation TENS and Hot Compress Devices Therapy to Relieve Pain

by Joga Setiawan

Submission date: 06-Jul-2020 07:19PM (UTC+0700)

Submission ID: 1354100645

File name: lation_TENS_and_Hot_Compress_Devices_Therapy_to_relieve_pain.pdf (501.74K)

Word count: 2941

Character count: 15678



ICAMST 2018

Integration of the Stimulation TENS and Hot Compress Devices Therapy to Relieve Pain

Joni Karmani^{a,b,*}, Munadi, Munadi^a, Joga Dharma Setiawan^a, Susilo Adi Widyanto^a,
Paryanto, Paryanto^a

^aDepartement of Mechanical Engineering, Diponegoro University, Jl.Prof. Soedarto, SH Tembalang Semarang.50275, Indonesia

^bDepartement of Mechanical Engineering, 17 Agustus 1945 University, Jl. Perjuangan 17 Cirebon.45135,Indonesia

Abstract

Various ages especially the elderly persons can suffer neuropathic pain. It causes discomfort able effects for the patient. It is necessary to treat it well, so it does not depend on medication treatment anymore. One of the methods for pain relief is a therapy which is using TENS, a device that can help relieve pain. Any cases explain that the pain is still experienced by the patient even have been treated using TENS. Then further research has developed, a hot compress method that gives rise to a sense of comfort for therapy patients.

© 2019 Elsevier Ltd. All rights reserved.

Peer-review under responsibility of the scientific committee of The 6th International Conference on Advanced Materials Science and Technology 2018, 6th ICAMST.

Keywords: pain therapy; TENS; heat compress; electrical; therapeutic

1. Introduction

Electric therapy or also called as electrotherapy is a therapeutic method for diseases and other health problems using electrical signals as a device of treatment. Electrotherapy is currently developed in the medical world as well as the development of the TENS method used for pain relief treatment in muscles and bones by blocking small fibers. TENS can stimulate the release of endorphins so that the pain can be blocked. These pain stimuli transfer

*Corresponding author. Tel.: +628-190-995-875 ; fax: +62- 231- 485-345.

E-mail address: joni_075@yahoo.com

precisely have been utilized by many inventors. The frequency provided by this device is adjusted to the mechanoreceptor excitatory threshold, with a stimulus rate of 90-130 Hz. The current intensity is usually set to reach 80-100 mA. The use of electrotherapy in alternative medicine has been going on for a long time, but it is underdeveloped. As the medical world, the electrotherapy uses only for a supportive therapy method [1]. Fig. 1. shows the TENS device.



Fig. 1. TENS

The latest report explains that the pain therapy using TENS was insufficient to reach the optimum results. To overcome this condition, it was proposed to combine with a heat compress therapy. Hot compress therapy is the treatment for chronic pain which has been suffered for more than 6 months [2]. Hot compress therapy is a surface therapy (superficial) which aims to dilate blood vessels, it might to improve blood circulation systems, in turn it could relieve pain [3]. In this way, the distribution of acids and foods ingredients to the cells may enlarged, and the removal of the disposed substances might be repaired. When this condition reached, it opens a better exchange of substances.

These two therapeutic processes or two modalities have been running to two different devices, whereas social insurance administration organization (BPJS) only covers a maximum of two therapies or modalities in a week. The purpose of the integration of TENS therapy and heat compresses is to relieve patients pain under one step [4-5]. Therefore, this study intends to build a device containing TENS and prepared hot compress therapy. We use heating films for heat compresses section. It is expected to reduce the number of patients with muscle pain from going to the hospital with long queues, especially for elderly persons. The therapeutic device designed can be implemented without any disrupting for daily activities.

2. Physiotherapy

There are many kinds of treatments to relieve pain for patients. One of them is the physical therapy called physiotherapy. The purpose is to improve motoric function due to interference the muscles and skeletons of the body after a fracture, or postoperative bone. Physiotherapy is also given to patients with neuropathic pain, such as diseases caused the wrong pattern of paths and weak muscles, and patients experienced to peripheral nerve disorders, inflammation of the lining of the brain, blockage of the channels in the brain, and others. In physiotherapy clinics, therapists will teach patients how to do the right body movements. These movements must be applied to the patients such as sitting, standing, walking, running.

The physiotherapist could recommend some techniques which could be employed to patients, including exercise therapy, heating therapy, electrical stimulation therapy, cold therapy, chest therapy, hydrotherapy, and orthopedic & rheumatoid arthritis. The therapy exercise is intended to restore function while it provides strength and maintenance of motion to gain to at least reach close to the normal conditions. The patient will be trained to hold and move their hands and feet. After being able to do the programmed of the first step exercise, it could be continued with the mobilization exercise such as standing, stepping, walking, and jogging. These exercises provide to maintain the muscles strength and their functional abilities preventing the joints stiffness. It is necessary to do because a broken leg fitted with a cast will generally experience muscle wasting in reducing strength. This therapy could overcome the reduced body's parts function.

The heat treatment therapy utilizes the heat energy which is usually used for skin, muscle, and other internal body systems. The application of heat treatment may adjusted as the level of complaints. For the purpose of the skin therapy we may employ *Infra-Red Radiation* (IRR) method. When the disorder occurs in the muscles we use a

micro diathermy. Meanwhile, when the disturbance appears an internal part of the body such as a skeleton we can use the short wave diathermy. The kind of therapy performed will be fitted to the results of the diagnosis. Heating therapy is usually implemented with other types of therapy, for example, the inhalation therapy for patients with mucus problems in the airways in muscle and joints pain. When it is combined with other forms of treatment, it is certainly more beneficial because the dose of medication that must be taken becomes smaller to minimize its negative effects.

The electrical stimulation therapy employ small electric currents which suitable for patients who suffer from muscle weakness due to fractures or nerves damage. The applications worked by attaching electricity to the muscles to relieve pain. This therapy aims to maintain muscle mass and indirectly stimulate nerve regeneration. In pediatric patients suffering from respiratory disorders, this therapy can also be used for treatment. The effect is that the blood circulation in the chest cavity and the respiratory tract becomes smoother so it promotes relaxation and removes mucus from the respiratory tract. This condition may accelerates the healing process.

2.1. Electrical stimulation therapy using TENS

Electric therapy is a treatment method based on the stimulation of pulses of electric currents to amperes with low voltage. It uses themilliampere currents close to bioelectric currents which occur naturally in the body therefore it is more effective in improving body systems repair and healing. The bioelectric currents are usually found in the order of microampere. The changes to bioelectric voltage potential across the muscle cell membrane allow for more efficient membrane transport and metabolic processes. Increasing cell permeability of sodium ions followed by increased permeability to potassium ions. Electric energy is needed for this process to occur in the muscle fiber. When a local stimulus is given near the surrounding membrane, changes occur in the ionic conductance of the membrane, which tends to restore potential at resting potential even if the stimulus persists [1].

TENS can be defined as a way of using electrical energy to stimulate the nervous system through the surface of the skin and has proven as an effective way in stimulating various types of pains. The purpose of therapy using TENS is to stimulate muscle physiology and prevent muscle atrophy, re-educate muscle function, sensory, spinal pain modulation, increase the range of motion (ROM) or stretch tendons, and facilitate blood circulation.

TENS has a monophonic pulse shape (rectangular waveforms, triangular and unidirectional sinus half waves), biphasic (symmetrical biphasic and sinusoidal symmetrical biphasic pulses), and polyphonic patterns (there are sine waves and interference or mixed forms). Monophonic pulses always have some results in the collection of pulses of electrical charge in the network, so that electrochemical reactions will occur in systems that are characterized by a sense of heat and pain if the use of intensity and duration is too high. TENS has a pulse frequency ranging from 1 to 200 seconds. The high pulse frequency of more than 100 pulses per second causes a contraction response and vibration sensibility, so the muscles get tired quickly. While low-frequency electric currents tend to be irritating to the skin system, yet the pain is suffered when it reaches the high intensity. Medium frequency electric currents are more conducive for electrical stimulation because they do not cause skin resistance or irritating and show a deeper penetration. Fig. 2. shows the TENS device.



Fig. 2. TENS



Fig. 3. Heat compresses

Furthermore, when it is related to the placement of TENS electrodes, placed around the location of pain, dermatome, trigger point area, and motor point. When electrodes are placed on the location of pain, this method is the easiest and most frequently used, because this method can be directly applied to the pain area without regard to the most optimal character and location about the system that is causing pain. Placement in the dermatome area

places at a specific location in the dermatome area. Furthermore, the TENS, a stimulus device, is an electrical device that works based on the principle of a signal generator with a set of the size of the frequency. A good stimulation device works as a current source controlled by voltage (Current Source Voltage Controlled) because the stimulation needed by the body is directed stimulation for the movement of body ions. The movement of these body ions about the electrical circuit of the body takes on the role of the body's electric currents as well as the movement of electrons in an electrical circuit in a conductor wire. In general, a stimulation device consists of signal therapy generator, therapy signal controller, the voltage to electric current converter, and patient safety module.

The electrical signal used in electric currents is an electric current pulse signal in milliamperes. The signals used for therapy have various forms, amplitude, frequency, and width of pulses (for pulse signals) depending on the use of therapy for certain diseases to be done. There are five basic forms of therapy for electric current namely bipolar square-half-wave relay, bipolar square relay, full bipolar square, bipolar half wave ramp, and bipolar ramp relay. The form of the signal is bipolar signals because the majority of the types of signals that are good to use are bipolar types in electrotherapy [6]. In addition to stimulation signals, other design parameters established by researchers in designing microcurrent stimulation signals are as follows. The amplitude, frequency, and pulse width respectively ranging from 0 to 1,000 μA , 0.25 to 500 Hz, and from 1 to 1,000 Ms.

The aspect which necessary to be considered in the design of modern current therapy signals is the occurrence of resonance between the therapeutic signals produced by the body's normal electrical activity and frequency. By controlling the four parameters, an electric currents therapy is given by paying attention to the value of the charge given to the body for each pulse. The microcurrent stimulation can be designed in such a way that it is effective in stimulating the body's physiological activity.

To calculate the electric currents, frequency, pulse width, electric charge, and the average electric current correctly, the calculation of modulus was implemented. The calculation of the electric charge and average electric current have been implemented as part of a safety system. Each stimulation signal generated the value of the electric charge is not allowed to exceed 20 μC , while the average electric currents is not allowed to exceed 4,000 μA . The calculation of the electric charge and the average electric current is given by equations 1 and 2.

$$q = \frac{I \cdot \tau}{1000} \quad (1)$$

$$I = \frac{1000 \cdot q}{\tau} \quad (2)$$

2.2. Thermotherapy

Thermotherapy is a method of therapy using heat power that has been widely used in the field of health which shown many benefits. There are two types of thermotherapy namely superficial (surface) thermotherapy, and deep thermotherapy. Superficial thermotherapy is applied using some devices such as infrared, moist heat packs or other superficial thermotherapy devices. On the other hand, deep thermotherapy is applied using some devices such as microwave diathermy, shortwave diathermy, and ultrasound.

Thermotherapy includes treatments with low risk and effective, and they do not require expensive costs named thermotherapy [4]. The application of heat to thermotherapy can relieve pain and stiffness through increased relaxation, joint flexibility and blood flow [8]. Patients with pain advised by doctors to conduct thermotherapy using a device or cloth independently at home, even if the patient is not at a homecare program. One of the examples of thermotherapy is heat compress in addition to use heat packs and some other heating systems. Hot compresses can be made and applied easily even only using simple items. Fig. 3. shows the therapy of heat compresses in people with osteoarthritis [7].

3. Results and discussions

In designing this device, the writers use heating film as a heating element, with heater film of 12V/20W. This component was used as a heater that is flexible to the laying position. To calculate the heating electrical power of the film in given by Equation 3.

$$P = V.I \tag{3}$$

where P, V and I designated as power, voltage, and current respectively. Furthermore, the film heating dimmer component is used to control the temperature regulator. The input is ranged of 6V-28 V while maximum output is 80W, with maximum continuous output is set to 3A. Other supporting components are LM35 temperature sensor, a 3.5 " TFT LCD 480X 320 display monitor module shield for Uno shield, and a DC 12 Volt 10 Ampere (12V- 10A) adapter that uses an adapter power supply switching. The research of this preliminary studies focused on the functional aspects of the device to produce the frequencies needed for TENS therapy and warm temperatures for the treatment of heat compresses. Fig. 4. shows a series of modality modules for TENS therapy and hot compress therapy produced in this initial study.

The next stage is testing the technical aspects of the function. The signal amplitude test was carried out. The signal amplitude represents the maximum electric current strength at the microampere current stimulation pulse. Signal amplitude testing aims to test the real strong electric current generated by the stimulation device, in which it has the real device data (0 to 1.000 μA) compared to the results of voltage measurements using an oscilloscope. The first trial of the TENS system was a test of protection against the excess electric charge. By the requirements of microcurrent electrotherapy, the value of the electrical charge is given to patients must not exceed 20 μC per pulse. The test results data of protection against excess electric charge is shown in Table 1.

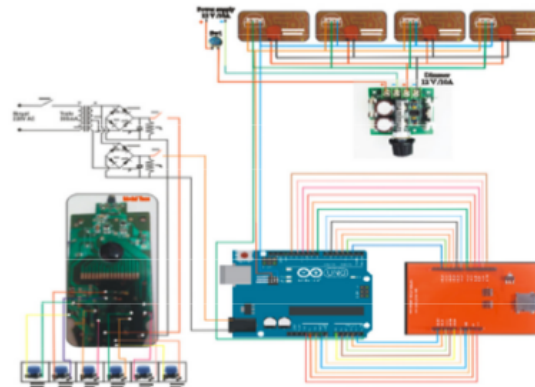

Fig. 4. Therapeutic device for one modality for TENS therapy and heat compresses

Table 1. Test of protection of excess electrical charges

RB Value (Ω)	Average voltage (mV)	Average flow (MA)	Pulse width (ms)	Load (μC)	% Current error	% Load error
100	18	180	4.24	0.76	0.82	0.96
330	341	1033	5.64	5.83	0.03	0.71
560	546	973	7.52	7.32	0.03	0.63
680	70	103	3.12	0.32	0.90	0.98
1000	-24	-24	4.16	0.10	1.02	1.00
Average current and load					0.56	0.86

4. Conclusion

We report of preliminary research on combining two modalities into an integrated therapeutic modality of a stimulus therapy modality (TENS) and hot compress therapy for pain treatment. The obtained device was able to provide a therapeutic frequency of 90-130 Hz which was produced from a current of 80-100 mA. While the film heater can produce heat reaching 40 °C with a voltage of 12Vdc. We further found that the average error was 0.56% for current errors and 0.86% for electrical load errors. The device is necessary to further test for the real patient to fulfill the requirements permitted by the medical association.

References

- [1] H. L. Peter, *Physiological Basis of Micro Current Therapy*, Bioelectric Medical Solutions, (2004) 1-3.
- [2] K.E. Nnoaham, J. Kumbang, *Cochrane Database of Syst Rev*, 3 (2010).
- [3] H. Seto, I. Hiroshi, H. Hidehiko, K. Hisashi, *J Ortho Sci*, 13 (2008) 187-191.
- [4] C.R. Denegar, D.R. Dougherty, E.J. Friedman, E.M. Schimizzi, E.J. Clark, B.A. Comstock, J.W. Kreemer, *Clin Inter Aging*, 5 (2010) 199-206.
- [5] P. E. Mancintyre, S.A. Schug, *Acute Pain Management: A Practical Guide*, Fourth Edition, CRC Press, China, 2014.
- [6] M. Joseph, Mercola, L. Daniel, Kirsch, *J Advancement in Medicine*, 8 (1995) 83 – 152.
- [7] Anies, *Waspada Ancaman Penyakit Tidak Menular Solusi Pencegahan dari Aspek Perilaku dan Lingkungan*, PT Elex Media Komputindo, (2006).
- [8] N. H. M. R. Council, *National Health Medical Research Council. NHMRC additional levels of evidence and grades for recommendations for developers of guidelines*. Canberra, 2009.
- [9] O. Tashani, M. I. Johnson, *MI, Libyan J. Med.*, 4 (2008) 62-65.

Integration of the Stimulation TENS and Hot Compress Devices Therapy to Relieve Pain

ORIGINALITY REPORT

1 %

SIMILARITY INDEX

%

INTERNET SOURCES

0 %

PUBLICATIONS

1 %

STUDENT PAPERS

MATCH ALL SOURCES (ONLY SELECTED SOURCE PRINTED)

< 1%

★ Submitted to University of Cumbria

Student Paper

Exclude quotes On

Exclude matches Off

Exclude bibliography On