

The Behavior of Reinforced Concrete Members with Section Enlargement Using Self-Compacting Concrete

Nuroji¹, Chung-Chan Hung², Blinka H. Prasetya³, Aylie Han¹

Abstract – This paper presents the experimental results of section enlargement effects on prismatic reinforced concrete members. 125 by 200 mm reinforced concrete members with a compressive strength of 20.3 MPa reinforced with D12 steel bars having a yield stress of 335 MPa situated in the tension and compression area, were produced. Two specimens were prepared, the first functioning as the control element and designated as the Control Beam (CB). The second strengthened with a section enlargement using Self-Compacting Concrete (SCC) marked as the Strengthened Beam (SB). The SCC had a 28-day compressive strength of 23.9 MPa. The dimensions of the enlarged beam were 200 by 300 mm. The two specimens CB and SB were tested with a two-point loading system. Based on the tests data, the load–displacement and moment–curvature relationships characterizing the beams were generated. From the results it was concluded that the enlargement affected the load-carrying capacity and stiffness positively. The SB member had a six times higher moment capacity, while the stiffness performance was enhanced seven times when compared to the CB specimen. On the other hand, it was also demonstrated that the ductility of the SB decreased as a consequence of the increase in span-to-depth ratio. The study was expanded based on the rational analyses to evaluate the influence of the additional tensile steel and concrete strength ratio of the enlarged section. **Copyright © 2020 Praise Worthy Prize S.r.l. - All rights reserved.**

Keywords: Flexural Member, Concrete Beam, Section-Enlargement, Self-Compacting Concrete, External Strengthening

Nomenclature

| | |
|---------------|--|
| a | Distance of vertical load to the supports (mm) |
| d | Effective depth of the section (mm) |
| f'_c | Cylindrical concrete strength (MPa) |
| f_y | Steel yield stress (MPa) |
| f_u | Ultimate steel yield strength (MPa) |
| ACI | American Concrete Institute |
| CB | Control Beam |
| D12 | Deformed steel bar diameter (mm) |
| $M_{ult-exp}$ | Experimental ultimate moment (kN m) |
| M_{ult-th} | Theoretical ultimate moment (kN m) |
| SB | Strengthened Beam |
| SCC | Self-Compacting Concrete |
| FRP | Fiber-Reinforced Polymers |
| LVDT | Linear Vertical Displacement Transducer |
| ρ | Tensile steel ratio to concrete |

I. Introduction

Structural strengthening is customarily aimed to fulfil the structure's capacity requirements originating from changes in code, increase in service load demands, or functional alterations of the structure [1]-[3]. Additional justifications include inappropriate or inaccurate design, deviations during the construction process, and structural damage caused by natural disaster or hazards such as

fires. A widely used strengthening technique involves superimposing external reinforcement, namely steel plates or Fiber-Reinforced Polymers (FRP) at the tension zone surface of the member, to increase the capacity and stiffness of the structure's element [4]-[9].

While external reinforcement is relatively easy and proven to be effective, researchers have reported cases of debonding and delaminating in the interface between the external reinforcing component and the concrete [10]-[15]. Other statements highlighted the presence of shear failure in the longitudinal direction and shifting from the flexural to the flexure–shear mode of failure. This will further affect the ductility behavior of the member [11], [16], [1], [17].

Further, the possibility of an alteration from under-reinforced to over-reinforced behavior should be accounted for.

The above-mentioned factors could lead to the premature collapse of the member, before the targeted load-carrying capacity is reached.

The use of section enlargement has many advantages when compared to the use of steel plates and FRP, since a better compatibility is achieved, while increased stiffness is guaranteed.

This research focuses on strengthening by section enlargement to enhance the flexural capacity of reinforced concrete members.

II. Outline and Research Review

The research work was based on experimental tests on strengthened beams. A detailed description of material properties and section dimensions were outlined, and interesting issues concerning the use of self-compaction concrete were highlighted. Then, the set-up of the experimental tests and the loading sequences and details of the precision apparatus that were utilized to evaluate the behavior of the member were explained. Data evaluation was distinguished into analyses of the load-displacement responses, the moment-curvature behavior, the failure mode and crack propagation pattern. Since multiple factors contributed to the observed behavior deviation, a numerical simulation to assess each influence was conducted. The conclusion summarizes the observed facts, and sheds a light on the positive and negative aspects of this strengthening system.

III. Research Methodology

Two perfectly identical 125 by 200 mm reinforced concrete beams with a length of 2.40 meters were cast, namely the Control Beam (CB) and the Strengthened Beam (SB). The latter was prepared for further treatment using Self-Compacting Concrete (SCC) to generate the external reinforcement [18], [19]. An average cylindrical concrete strength f'_c of 20.3 MPa was obtained from five test cylinders, cast during the process and tested at the age of 56 days. This concrete age difference with the SCC was to simulate the actual condition in the field, where the enlargement part is cast at a later stage. The steel reinforcement bars were tested. The primary reinforcement D12 had a yield stress f_y of 335 MPa and an ultimate strength of 497 MPa. The stirrups were placed 150 mm apart and had a diameter of 6 mm. The yield stress and ultimate strength were measured to be 363 MPa and 535 MPa respectively. All specimens were kept moist for 28 days to ensure that no micro-cracks developed in the member. The SB specimen was then strengthened by enlarging the section and placement of the additional longitudinal reinforcing bars.

Supplementary shear reinforcement had to be added to ensure that the failure mode remained in flexure. The stirrups were located parallel to the original stirrups and had the same diameter and spacing as the original configuration. To achieve stability within the core and to create a confined area to help prevent debonding, two 8 mm steel bars were placed longitudinally, on the transversal side of the enlarged section, as can be seen in Figs. 1. These bars had a yield stress f_y and ultimate strength f_u of 362 MPa and 518 MPa respectively. The CB specimen remained in its original state. The section enlargement of the tensile area was mainly to improve the stiffness of the member and to enlarge the moment capacity through the moment contribution of the additional tensile steel. The 37.5 mm enlargement on the left and right side of the original member was mainly to accommodate the process of casting, and to house the secondary shear reinforcements.

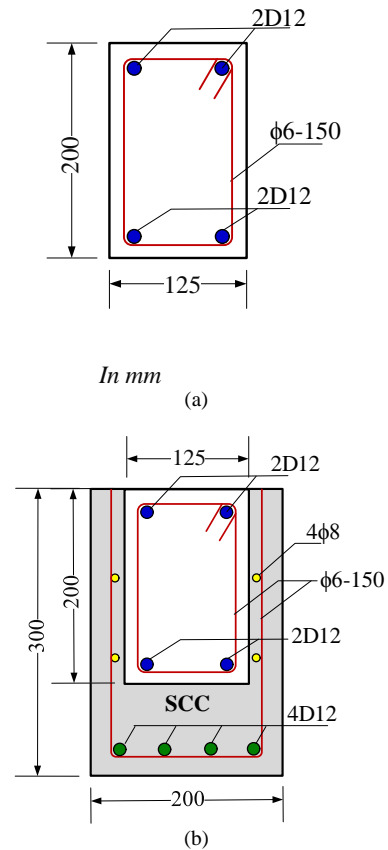

Figs. 1. Details of (a) CB and (b) SB

The enlarged section was constructed using SCC. This became a necessity due to the limitation in casting space, measuring only 37.5 mm at each side of the section, whereas the bottom part that had to be filled was substantially larger, measuring 100 mm in depth. The very narrow spacing between the reinforcing steel bars also made the production of a well-compacted enlarged section a challenge. The solution was to use a very high flowable SCC. The flowability of SCC was measured by the slump flow method, and an average measurement of 650 mm as shown in Fig. 2 was obtained. In accordance with the ACI 237R code, a minimum of 600 mm is mandated for a concrete mix designated as SCC. The average 28-day compressive strength of three SCC cylinders was 23.9 MPa, which was slightly higher than the CB concrete strength.



Fig. 2. SCC flowability measurement

IV. Experimental Set-Up

To observe the specimen's flexural behavior, both the specimens were subjected to a two-point loading system with a 450 mm load-to-load distance. This simply supported set-up was favored to ensure a state of pure-flexure in between the lines of loading. The load distance to the effective section depth ratio a/d was designed to a minimum of 3, to minimize the shear response within the element. The supports were located at a distance of 75 mm from the far ends of the beam. The load was induced, and controlled by a hydraulic jack producing an increment loading rate of 2.00 kN/minute. The load response was recorded by a load cell. Five LVDTs were utilized, one to measure the vertical displacement at mid-span and two pairs of LVDTs located longitudinally on each face at mid-span to measure the relative displacement in the compression and tension zone (Fig. 3). The horizontal average strain could further be calculated from the comparative displacement between the two opposite LVDTs, divided by their distance. The curvature was determined as the horizontal average strain ratio to the distance of the horizontal LVDTs in the compression and tension zone (Fig. 4). Strain gauges were attached on the extreme compression concrete fibers and the reinforcing bars to record the strain. All devices were connected to a data logger.

V. Analysis and Discussion

V.1. Load-Carrying Capacity Behavior

The test specimens CB and SB were tested monotonically up till failure. In Fig. 4 the load-displacement relationships at mid-span are shown. The SB specimen differs significantly from CB in terms of the ultimate loading capacity, initial stiffness and ductility behavior. The ultimate load of SB was measured to be 145 kN, compared to the 26 kN that could be carried by CB. A 5.6 times higher capacity is reached for a depth ratio of 1.5 and a tensile reinforcement ratio increase of 0.002. The capacity increase is a contribution of the additional tensile steel reinforcement, the 1.6 concrete compression-width-ratio enlargement, and the

shifting of the neutral axis downwards. Secondary points that could influence the moment capacity are the presence of longitudinal steel bars that, to a degree, subsidized the tensile capacity to the member, since the neutral axis fell above the two rows of longitudinal steel bars. The stirrups in the enlarged section provided confinement to the compression zone of the member, while on the other hand this confinement also postponed the delaminating process in the interface to some extent.

The span-to-depth ratio of the enlarged member also has an impact on the enhancement behavior. To investigate the contribution of these factors, a theoretical simulation was conducted, the results of which are shown in Table I. The additional stirrup had a confining effect on the concrete [20]-[24]; the analysis was based on the assumption of a 20% increase of compression strength in the compression area, especially since the stirrups were extending into the extreme concrete fibers in compression.

The additional stirrup had a confining effect on the concrete [20]-[24]; the analysis was based on the assumption of a 20% increase of compression strength in the compression area, especially since the stirrups were extending into the extreme concrete fibers in compression. This was proven to be effective for the case of confinement of the flexural element [17]. To study the contribution of the additional steel reinforcement, the moment capacity as a function of a variation in steel tensile ratio ρ was determined and is shown in Fig. 5(a).

The case with zero additional reinforcement in the extended section resulted in a moment capacity of 18.8 kN m. Since the original CB section had a theoretical moment capacity of 12.1 kN m, the contribution of the enlarged section was 6.7 kN m, responsible for only 12% of the capacity enhancement. The concrete enlargement had little effect on the behavior of the overall strengthened beam. This finding underlined that the supplementary tensile reinforcement contributes the most to the increase in performance. It can also be concluded from the pattern of reinforcement ratio that the increase effect follows a straight line. Fig. 5(b) illustrates the provision of concrete strengthening to the capacity of the beam.

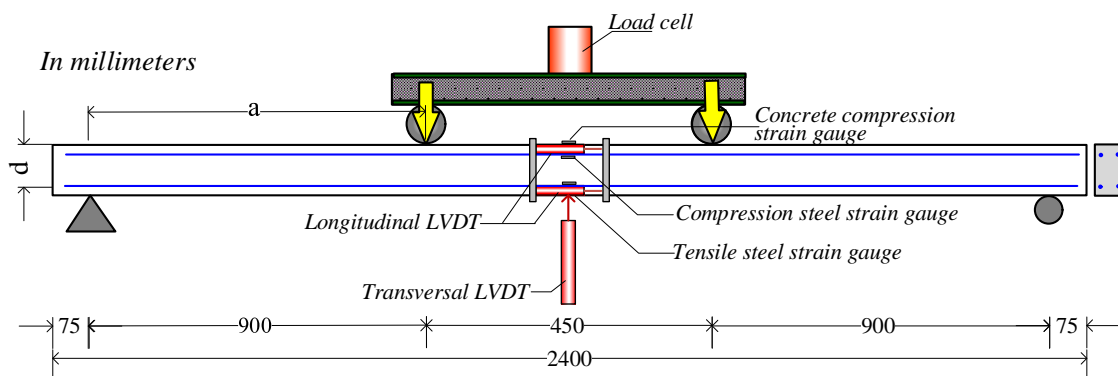

Fig. 3. Experimental set-up

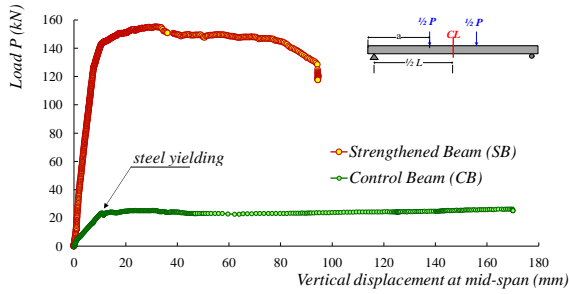
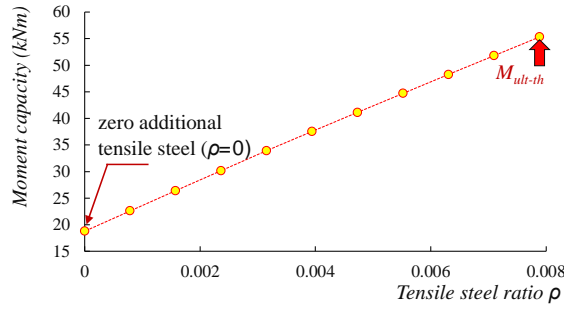
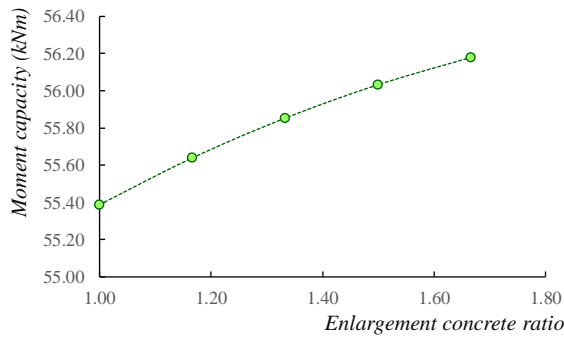

Fig. 4. Load-displacement reponses of CB and SB



(a)



(b)

Figs. 5. Influence of (a) reinforcement ratio and (b) concrete strength ratio

TABLE I
EXPERIMENTAL AND ANALYTICAL RESULTS

| Specimen | $M_{ult-exp}$ (kN m) | M_{ult-th} (kN m) | Deviation ratio to experiment | Neutral axis to the compression fibers (mm) |
|----------|----------------------|---------------------|-------------------------------|---|
| CB | 11.8 | 12.1 | 0.03 | 34 |
| SB | 69.8 | 55.3 | -0.21 | 37 |

It is shown that the enhancement pattern followed a concave trajectory influenced by the non-linear behavior of the concrete. The contribution of the increase of concrete compression strength to the capacity of the member was diminishing, and a concrete strength of 50 MPa resulted in only a 1.4% improvement in the load-carrying capacity for the member.

V.2. Moment-Curvature and Cracking Pattern

Fig. 6 presents the moment–curvature behavior of the beams.

The curves present a similar pattern to the load–displacement relationships.

The SB specimen has an almost zero curvature at early loading stages, underlining the very high stiffness of the member. It can also be demonstrated that in the elastic range, the stiffness of specimen SB is 5.4 times higher than CB.

The ultimate curvature, however, is only 0.7 for CB.

The origin of this divergence is influenced by the span-to-depth ratio (a/d), and the effective depth of the SB member is 50% higher than that of CB due to section enlargement. Tensile steel yielding of specimens CB and SB was found at curvatures of 0.016615 rad/mm and 0.016615 rad/mm, respectively.

Fig. 7(a) shows the crack pattern of both the specimens. Crushing of concrete in the compression zone is clearly seen.

To evaluate the disparity in cracking modes between CB and SB, a graphical representation is presented in Figs. 7(b) and 7(c). The cracks were marked in the order of the loading sequence under which the cracks appear. Beam CB underwent the first cracking at very low loading levels as small as 12 kN.

The cracks increased in number, and propagated vertically towards the neutral axis of the beam. Beam SB experienced the first cracks at a much higher load level.

The recorded load was measured to be 54 kN, and horizontal expansion as well as vertical crack propagation occurred almost simultaneously. Examining the crack trajectory, it can be seen that beam SB exhibited extended flexure–shear cracks in the line of applied loads, while beam CB has an unmistakable flexure failure behavior. In changing the section’s depth-to-width ratio, the failure mode shifted away from the flexure behavior [25].

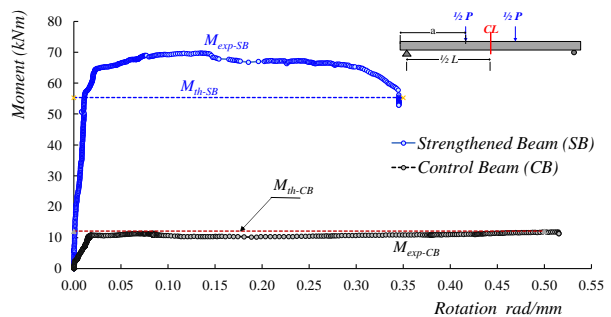
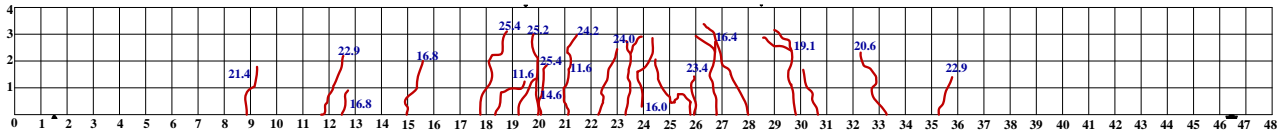

Fig. 6. Moment-rotation behavior of CB and SB and theoretical capacity



(a)



(b)

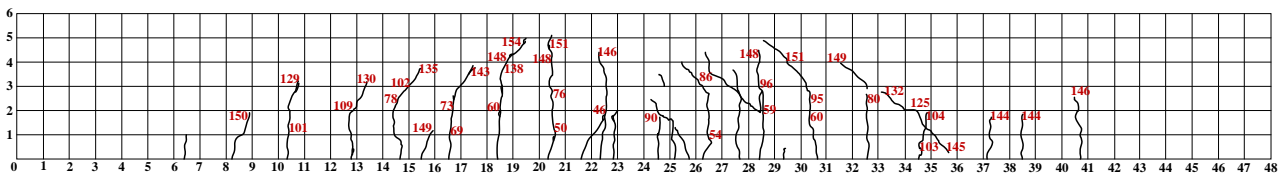

(c)

Figs. 7. (a) Cracking pattern of CB and SB (b) Graphical presentation of CB (c) Graphical presentation of SB

VI. Conclusion

The method of capacity enhancement using concrete section enlargement has proven to be very effective in increasing the moment-carrying capacity and stiffness of the beam. The method is less expensive than strengthening using fiber-reinforced plastics or steel, and the debonding phenomenon can be controlled. However, the ultimate ductility of the newly obtained member reduced significantly. Rational analysis of both sections revealed that, even though the effect of confinement in the compression zone and the contribution of longitudinal reinforcement were accounted for, other factors, yet to be determined, resulted in a less accurate prediction of the SB specimen's ultimate moment capacity. Further evaluation of the contribution of the additional reinforcing steel disclosed that the increase in capacity was dominated by this steel, while the stiffness improvement was a provision of the concrete. The rate of capacity increase as a function of the reinforcement ratio followed a linear path, while the influence of the concrete strength ratio followed a quadratic path, designated by the characteristics of the non-linear concrete behavior. The use of high-strength concrete was proven to be insignificant and contributed only very little to the moment capacity of a member. This strengthening method has the potential to alter the failure mode of the beam, shown from the deviations in cracking patterns between CB and SB. The method described in this study is only effective for positive bending moments.

Contradictory to strengthening with fibers, this method cannot easily be applied at near-beam-column areas since it will create a physical change to the inhabited space of a building. The response of this

strengthening technique is also the subject of further investigation into the combination of high shear stresses with high flexural stresses, since the two-point loading system creates a pure flexure state between the line of loads.

Acknowledgements

The authors express their gratitude to the Dean and the Department Head of the Civil Engineering Department, Engineering Faculty, Diponegoro University for providing the DIPA funding that made this research work possible.

References

- [1] Attari N., Amziane S., Chemrouk M., Flexural Strengthening of Concrete Beams Using CFRP, GFRP and Hybrid FRP Sheets, *Construction and Building Materials*, Vol. 37:746–757, December 2012.
doi: <https://doi.org/10.1016/j.conbuildmat.2012.07.052>
- [2] Wang Y., Yang S., Han M., Yang X., Experimental Study of Section Enlargement with Reinforced Concrete to Increase Shear Capacity for Damaged Reinforced Concrete Beams, *Applied Mechanics and Materials*, Vol. 256-259: 1148-1153, 2013.
<https://doi.org/10.4028/www.scientific.net/AMM.256-259.1148>
- [3] Zhang H.Y., Yan J., Kodur V., Cao L., Mechanical behavior of concrete beams shear strengthened with textile reinforced geopolymer mortar, *Engineering Structures*, Vol. 196, Art. 109348, October 2019.
doi: <https://doi.org/10.1016/j.engstruct.2019.109348>
- [4] Vatovec M., Kelley P.L., Alkhrdaji T., and Nanni A., Evaluation and CFRP Strengthening of Existing Garage: Case Study, *ASCE Journal of Composites for Construction*, Vol. 6(3), 184 – 193, 2002.
doi: [https://doi.org/10.1061/\(ASCE\)1090-0268\(2002\)6:3\(184\)](https://doi.org/10.1061/(ASCE)1090-0268(2002)6:3(184))
- [5] Zhang Y., *Repair and Strengthening of Reinforced Concrete Beams*, Honors Thesis, The Ohio State University, 2012.

- [6] Li L., Lo S. H., Su R.K.-L., Study of Moderately Reinforced Concrete Beams Strengthened by Bolted-Side Steel Plates, *Design, Fabrication and Economy of Metal Structures*, Ch. 86, Springer Berlin Heidelberg (2013).
doi: <https://doi.org/10.1007/978-3-642-36691-8>
- [7] Demir A., Ercan E., Demir D.D., Strengthening of reinforced concrete beams using external steel members, *Steel and Composite Structures*, Vol. 27 (4), 453-464, May 2018.
doi: <https://doi.org/10.12989/scs.2018.27.4.453>
- [8] Djeddi, F., Ghernouti, Y., Abdelaziz, Y., Experimental Investigation of FRP-Concrete Hybrid Beams, (2015) *International Review of Civil Engineering (IRECE)*, 6 (6), pp. 151-155.
doi: <https://doi.org/10.15866/irece.v6i6.8187>
- [9] Tbatou, T., El Youbi, M., Dynamic and Structural Study of a RC Building Braced by FRP Composite Materials, (2020) *International Review of Civil Engineering (IRECE)*, 11 (1), pp. 1-9.
doi: <https://doi.org/10.15866/irece.v11i1.16991>
- [10] Leung C.K.Y., FRP Debonding from a Concrete Substrate: Some Recent Findings Against Conventional Belief, *Cement & Concrete Composites*, Vol. 28 (8): 742–748, September 2006.
doi: <https://doi.org/10.1016/j.cemconcomp.2006.05.015>
- [11] Ceroni F., Experimental Performances of RC Beams Strengthened with FRP Materials. *Construction and Building Materials* Vol. 24 (9):1547–1559, September 2010.
doi: <https://doi.org/10.1016/j.conbuildmat.2010.03.008>
- [12] Spadea G., Bencardino F., Sorrenti F., Swamy R.N., Structural Effectiveness of FRP Materials in Strengthening RC Beams, *Engineering Structures*, Vol. 99:631–641, 2015.
doi: <https://doi.org/10.1016/j.engstruct.2015.05.021>
- [13] Sri T., Han A.L., Banu A.H., An Experimental Study to the Influence of Fiber Reinforced Polymer (FRP) Confinement on Beams Subjected to Bending and Shear, *Procedia Engineering*, Vol. 125:1070-1075, 2015.
doi: <https://doi.org/10.1016/j.proeng.2015.11.164>
- [14] Sri T., Han A.L., Buntara S.G., Revitalization of Cracked Flexural Members Using Retrofitting and Synthetic Wrapping, *Procedia Engineering*, Vol. 171:1123-1128, 2017.
doi: <https://doi.org/10.1016/j.proeng.2017.01.472>
- [15] Bekkar, I., Djermane, M., Bounoua, T., Repairing of Reinforced Concrete Beam by Composite Plate, (2016) *International Review of Civil Engineering (IRECE)*, 7 (1), pp. 1-4.
doi: <https://doi.org/10.15866/irece.v7i1.5633>
- [16] Ceroni F., Ianniciello M., Pecce M., Bond Behavior of FRP Carbon Plates Externally Bonded Over Steel and Concrete Elements: Experimental Outcomes and Numerical Investigations, *Composites, Part B*, Vol. 92:434–446, May 2016.
doi: <https://doi.org/10.1016/j.compositesb.2016.02.033>
- [17] Huang L., Yan B., Yan L., Xu Q., Haozhi, Kasal B., Reinforced concrete beams strengthened with externally bonded natural flax FRP plates, *Composites, Part B*, Vol. 91:569–578, April 2016.
doi: <https://doi.org/10.1016/j.compositesb.2016.02.014>
- [18] Ghazy M.F., Performance of Self Compacting Concrete, *Ain Shams Journal of Civil Engineering (ASJCE)*, Vol. 2:23-39, September 2009.
- [19] Mittal M., Basu S., Sofi A., Effect of Sika Viscocrete on Properties of Concrete, *International Journal of Civil Engineering (IJCE)*, Vol. 2 (4):61-66, September 2013.
- [20] Han A., Antonius, Okiyarta A.W., Experimental Study of Steel-fiber Reinforced Concrete Beams with Confinement, *Procedia Engineering*, Vol. 125:1030-1035, 2015.
doi: <https://doi.org/10.1016/j.proeng.2015.11.158>
- [21] Bouamra Y., Ait Tahar K., Mechanical performance of a confined reinforced concrete beam, *Procedia Structural Integrity*, Vol. 5:155-162, 2017.
doi: <https://doi.org/10.1016/j.prostr.2017.07.086>
- [22] Huang L., Zhang C., Yan L., Kasal B., Flexural behavior of U-shape FRP profile-RC composite beams with inner GFRP tube confinement at concrete compression zone, *Composite Structures*, Vol. 184:674-687, January 2018.
doi: <https://doi.org/10.1016/j.compstruct.2017.10.029>
- [23] Moodi Y., Sohrabi M.R., Mousavi S.R., Effects of stirrups in spliced region on the bond strength of corroded splices in reinforced concrete (RC) beams, *Construction and Building Materials*, Vol. 230, Art. 116873, January 2020.
doi: <https://doi.org/10.1016/j.conbuildmat.2019.116873>
- [24] Hung C. C., Chen, Y. S., Innovative ECC Jacketing for Retrofitting Shear-Deficient RC Members. *Construction & Building Materials*. Vol.111: 408-418, 2016.
doi: <https://doi.org/10.1016/j.conbuildmat.2016.02.077>
- [25] Słowik, M., The Influence of Effective Length on Shear Failure in Concrete Beams, (2017) *International Journal of Earthquake Engineering and Hazard Mitigation (IREHM)*, 5 (4), pp. 117-123.

Authors' information

¹Engineering Faculty, Diponegoro University, Semarang, Indonesia.

²Department of Civil Engineering, National Cheng Kung University, Tainan, Taiwan.

³Magister Program in Civil Engineering, Diponegoro University.



Nuroji was born in Pemalang, Indonesia. He obtained his bachelor's degree from the Diponegoro University and his Master and Doctorate from the ITB in Bandung, Indonesia. Nuroji is an associate professor in structural and material engineering, and specialized in concrete innovations and modeling. An active member of the Indonesian Structural Engineering Association (HAKI), Nuroji has served as consultant for numerous projects with complicated design structures. His most recent research work involves strengthening and external reinforcement of beams and frames.



Chung-Chan Hung obtained his Ph.D. from the University of Michigan, Ann Arbor, USA and is an active member and editor of the ASCE Journal of Structural Engineering. He is also Chair of the Committee on International and Cross-strait Affairs for Taiwan Concrete Institute. Prof. Hung research is in the field of durable and sustainable concrete infrastructure. He is particularly interested in the development of advanced cement-based materials and earthquake-resistant RC structures. To investigate his research problems, Prof. Hung applies materials and large-structural tests, hybrid tests, and computational modeling techniques.



Blinka H. Prasetya was born in Semarang, Indonesia, 24 November 1995. He completed his bachelor in Civil Engineering from Diponegoro University cum laude. Currently, he studies at Magister Program in Civil Engineering, Diponegoro University. Prasetya is a research assistant at the Material and Construction Laboratory of the Civil Engineering Department, Diponegoro University. His major interests are concrete structures and structural systems

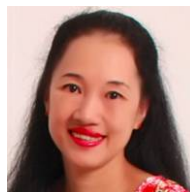

Aylic Han was born in Semarang-Indonesia. She completed her doctoral degree in Structural Engineering at Diponegoro University in a joint research with the National University of Singapore and North Carolina State University (USA). Currently a professor in civil engineering at the Diponegoro University, Semarang-Indonesia. Her research interests include concrete technology, graded concrete, and finite element modelling. As a researcher, she works with the NCKU in Tainan-Taiwan, and other state and private universities in Indonesia. Han Ay Lie is also the president of *fib*-Indonesia and a member of *fib* COM7-Sustainability, while serving as board for HAKI (the Indonesian Association of Structural Engineers). She is also a member of the new Indonesian Concrete Code (SNI 2020) formulation team and a long-time member of ACI.