

PAPER • OPEN ACCESS

Study of the effect on the addition of anti-slamming bulbous bow to total resistance in tugging supply vessel using CFD

To cite this article: Kiryanto *et al* 2021 *IOP Conf. Ser.: Earth Environ. Sci.* **698** 012007

View the [article online](#) for updates and enhancements.

You may also like

- [Stability analysis of trawls type traditional fishing boat with modification of eco-friendly fishing-gear on the north coast of Central Java](#)
Kiryanto, M Ridwan, B A Aditya et al.
- [Numerical Simulation Study of the Water Entry Slamming on Oscillating Buoys with Different Shapes](#)
Xuejian Li, Xing Luo, Ruohong Wang et al.
- [Parameter estimation of a breaking wave slamming load model using Monte Carlo simulation](#)
Shaofeng Wang, Torben Juul Larsen and Ove Tobias Gudmestad



The advertisement features a dark blue background on the left with white and orange text, and a photograph of a woman at a podium on the right. The woman is smiling and looking towards the camera. The background of the photo is a bright, modern interior with large windows.

ECS The Electrochemical Society
Advancing solid state & electrochemical science & technology

243rd Meeting with SOFC-XVIII

Boston, MA • May 28 – June 2, 2023

Accelerate scientific discovery!

Learn More & Register

Study of the effect on the addition of anti-slamming bulbous bow to total resistance in tugging supply vessel using CFD

Kiryanto¹, Deddy Chrismianto¹, Eko Sasmito Hadi¹, Ahmad Firdhaus¹

²Naval Architecture Department, Faculty of Engineering, Diponegoro University, Semarang, Indonesia

Email: kiryantodst@yahoo.com

Abstract. Anti-Slamming Bulbous Bow (ASB) is a bulbous bow that has been modified according to the Anti-Slamming principle. For waters that have varying wave heights, for example, in the East Nusa Tenggara region where waters meet the criteria for the application of anti-slamming technology and are related to the existence of several offshore buildings and the use of tugging supply vessels (AHTS) for the benefit of the region. This research was conducted to determine the effect of installing anti-slamming bulbous bow and Anti-slamming height on the total resistance of the ship using numerical methods with the help of CFD software. The method used is to vary the height of anti-slamming and the type of bulbous bow on the bow of the ship. Ship modeling is carried out with CAD Software, and while the obstacle analysis uses CFD Tdyn software. Based on the analysis that has been done, the effect of the anti-slamming bulbous bow on the total resistance value of the ship without an anti-slamming bulbous bow is reduced by 3.75%. The ship model, with the use of the anti-slamming bulbous bow, which has the smallest total resistance, is the ship with the form of anti-slimming bulbous bow type Delta (Δ - Type).

1. Introduction

With respect to the challenges of petroleum exhaustion and global warming, international regulations, such as the energy efficiency design index (EEDI) and ship energy efficiency management plan (SEEMP, 1961), were enacted to a decrease the growth rate of fuel consumption and greenhouse gas (GHG) emission in the shipping industry [1].

The main challenge in designing ships is the difficulty of achieving optimum efficiency, both in economics and performance. One of the efficient design optimization targets is how to get the optimum ship speed with the lowest possible use of engine power. So the calculation of the total resistance value of the ship when the ship operates becomes essential to be taken into account.

In obtaining an excellent design to reduce resistance, an addition was made to the bow section in the form of a bulge, also called a bulbous bow, which was able to reduce the drag 10% to 15% on a monohull ship [2]. Also, when sailing the ship's hull will definitely receive dynamic loads caused by waves that change every time, there is a time when the hull structure will experience a breakdown due to the continuous dynamic load that causes damage to the hull structure, one of the causes is the slamming effect.

When facing waves from the front, the ship will experience vertical unidirectional movement which causes the phenomenon of green water and slamming. Green water phenomenon is an event where the deck on the bow of a ship is touched by sea level. While the phenomenon of Slamming is an event where the basic direction. the ship was lifted from the surface of the water then crashing again. Both of these phenomena are used as one item to evaluate the seakeeping quality of a ship. Greenwater and Slamming



can disturb the stability of a ship's structure [3]. Even in extreme conditions, slamming can cause damage to the ship's structure [4].

In previous studies [5], the bulbous bow was applied to the bow Anti-Slamming bow, which has a lower base compared to the bottom of the ship's hull (below the ship's baseline). This modeling can reduce the ship's wave resistance by about 15-20%.

While the results of research [6], that did the modeling of Anti Slamming bulbous bow against obstacles and motion with a high variation of anti-slamming get a reduction in the value of obstacles 1.91 to 3.65% and a reduction in the value of the slamming probability of 10.60-12.21% against the original model. In this study, the focus is to analyse the resistance and motion of the ship due to the variation of anti-slamming bulbous bow height of the ship, to get the smallest value of resistance

2. Literature Review

Supply Boat (Anchor Handling Tug Supply / AHTS) is a type of ship specially designed to serve offshore exploration work (offshore). This supply ship has unique characteristics, including a relatively small hull with considerable main engine power, a double propeller system, and is equipped with a front-drive engine (Bow Thruster Engine). Other work equipment in the form of Anchor, Towing Winch Engine and tank equipment for bulk material (Bulk Material Tank) and other equipment.

2.1. Characteristics of a bulbous bow

A bulbous bow is a ball-shaped bulge located on the stern (front) of a ship only at the bottom of the waterline. Modifying the bow section by flowing water around the hull, reducing friction, and thereby increasing speed, full efficiency, and stability. Large ships with bulbous bow generally have about 12-15% more efficient than ships without the bulbous bow.

The types of the bulbous bow are divided into three types, namely:

- Delta Type (Δ – Type)
This type is suitable for ships that sail in areas that are less exposed to large waves.
- Oval Type (O – Type)
This type of bulbous is more widely used in ships with the shape of the "U" or fat-sized vessels.
- Nabla Type (∇ – Type)
This type is suitable for ships facing waves in the open sea. This form is often combined on ships with the ivory "V" used on high-speed vessels.

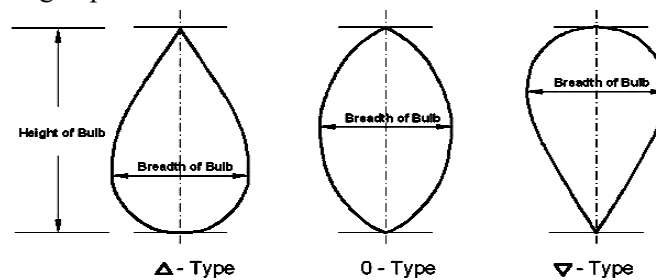

Figure 1. Bulbous bow type

To determine the dimensions of the various size of the bulbous bow is based on the Linear Form Coefficient parameter [5] states that Linear Form Coefficient is as follows:

- Breadth Coefficients (CBB) : $\frac{B_B}{B}$ (1)

- Length Coefficients (CLPR) : $\frac{L_{LPR}}{L_{PP}}$ (2)

- Height Coefficients (CZB) : $\frac{Z_B}{T_{FP}}$ (3)

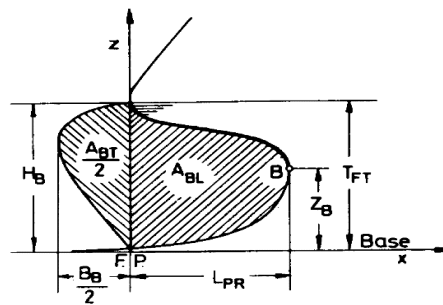

Figure 2. Bulbous Bow Parameters

While the specific values of the linear form coefficients are as follows (Ventura, 2003):

Table 1. Value of Linear Form Coefficients

<i>Linear Form Coefficient</i>	
C_{BB}	0,17 – 0,2
C_{LPR}	0,018 – 0,031
C_{ZB}	0,26 – 0,55

Anti-slamming bulbous bow is a form of bow ship equipped with a bulbous bow that functions in addition to intervening waves coming from the front of the ship; also, the bulbous bow has the function of reducing the chance of slamming.

2.2. Total Resistance

Ships resistance to moving on the surface of the water consists of two main components, namely normal stress, and tangential stress. The average voltage is related to wave-making and viscous voltage, while the shear stress is caused by the viscosity of the fluid. Ship resistance is the fluid force on the ship in the opposite direction to the ship's movement at a certain speed [8].

Then Molland simplifies the resistance component in two main groups, namely viscous resistance and wave resistance [9]. Calculation of obstacles using Tdyn software and comparison of obstacles using the Maxsurf software Van Oortmerssen method. The total ship resistance consists of several components, as shown in the diagram below.

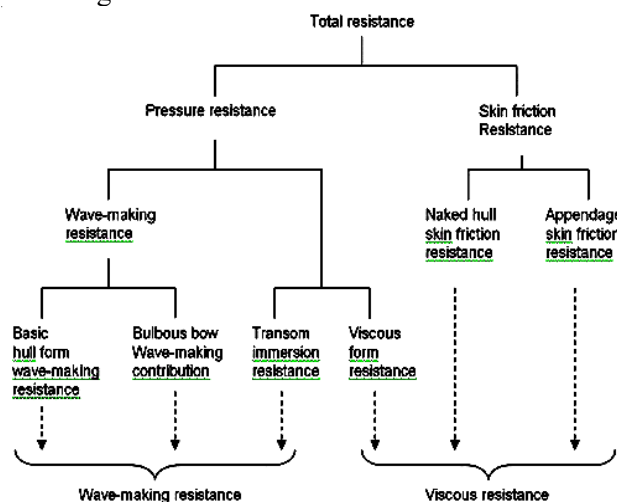

Figure 3. Resistance component diagram

Ship resistance is an essential factor that determines the power of the ship needed [10]. Ship resistance is the study of fluid reactions due to the movement of the ship through the fluid. In terms of hydrodynamics, the ship is the amount of fluid force acting on the ship in such a way that it opposes the movement of the ship. The primary and most significant factor is the hull geometry and the wet surface

of the vessel [11]. The resistance is the same as the force component that works parallel to the axis of the ship's velocity. The total resistance on the vessel can be stated as follows.

$$R_T = 0.5C_T V_S^2 S \quad (4)$$

2.3. Computational Fluid Dynamics

Computational Fluid Dynamics (CFD) is an analysis system that includes fluid flow, heat transfer, and related phenomena. As a chemical reaction by using computer-based simulation (numeric). This technique is advantageous and can be applied in industrial and non-industrial fields. CFD codes are structured on numerical logarithms, so they can be used to solve problems in a fluid flow. Computational Fluid Dynamics Code here consists of three main elements namely

- Pre Processor.
- Solver Manager.
- Post Processor (Visualize).

3. Analysis and discussion

Vessel modelling is carried out for the analysis of total ship resistance based on variations in bulbous bow type and anti-slamming height

The following are the main dimension of supply vessels which are the objects of research:

Table 2. Main Dimension

Item	Size (m)
<i>Length Over All</i> (LOA)	60,00 m
<i>Breadth</i> (B)	16,00 m
<i>Depth</i> (H)	6,00 m
<i>Draft</i> (T)	4,80 m
<i>Speed</i> (Vs)	12,50 Knot

The size of the bow shape to be used are as follows:

- Long Bulbous bow (L_{LPR})
 $L_{LPR} = C_{LPR} \times L_{PP} = L_{LPR} = 0.031 \times 53.9 = 1.67 \text{ m}$
- Bulbous bow height (ZB)
 $L_{ZB} = C_{ZB} \times T = L_{ZB} (B) = 0.405 \times 4.8 = 1.944 \text{ m}$
- Bulbous bow width (L_{BB})
 $L_{BB} = C_{BB} \times B = L_{BB} = 0.17 \times 16 = 2.76 \text{ m}$

Then the height of the anti-Slamming bulbous bow used is as follows:

$$H = 25\% \times T = 25\% \times 4.8 = 1.20 \text{ m}$$

$$\text{Length of Anti-Slamming Bulbous Bow } 20\% \times L_{WL} = 20\% \times 58.7 = 11.73 \text{ meters.}$$

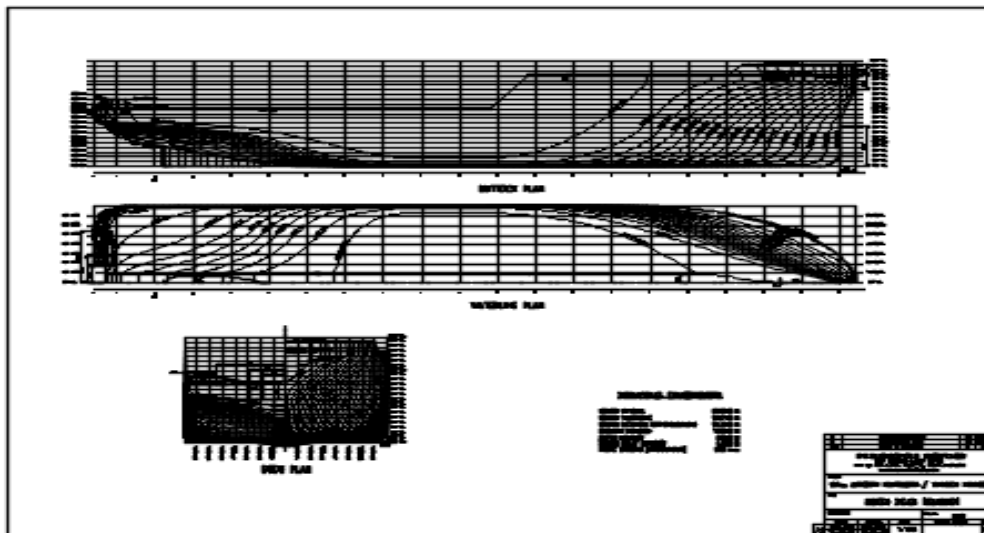

Figure 4. Ship linesplan data

Referring to the ship data used in this study, the next dimension and modeling are made with variations in the type of bulbous bow with the help of the Maxsurf Modeler Advanced Software

From the data and lines plan made a hull model with the help of Maxsurf Modeler Advance. The shape of the bulbous bow used in this study is the form of bulbous bow ∇ (Nabla type), O (Oval type), and Δ (Delta type). From the variations that have been determined above, we get the following ship models of the Anti-Slamming Bulbous Bow shape:

- Nabla (∇) type bulbous bow ship.

Model ship with Nabla bulbous bow type bulbous bow dimensions with length $L_{LPR} = 1.67$ m, width $B_B = 2.76$ m, $Z_B = 1.944$ m and length of Anti-Slamming bulbous bow $P = 11.73$ m, height $H = 1, 20$ m.

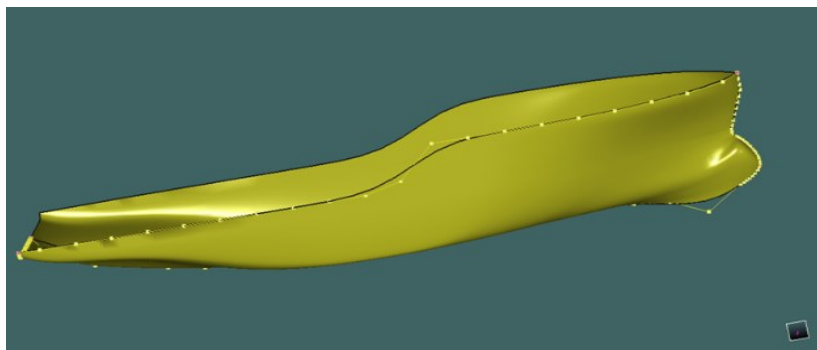

Figure 5. 3D Model of Nabla V type Bulbous Bow

- Model ship with Oval (O) bulbous bow.

Model ship with Oval (O) bulbous bow. bulbous bow dimensions are $L_{LPR} = 1.67$ m length, B_B width = 2.76 m, $Z_B = 1.944$ m with Anti-Slamming Length P bulbous bow $P = 11.73$ m, and height $H = 1.20$ m.

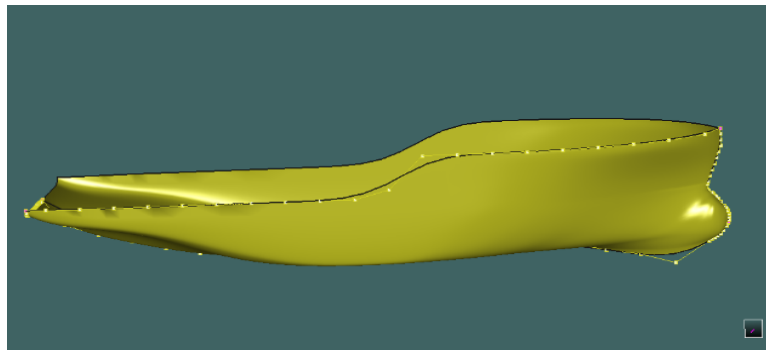

Figure 6. 3D Model of Oval (O) Bulbous Bow.

- Model ship with Delta type bulbous bow

Model ships with Delta type bulbous bow Δ bulbous bow dimensions are $L_{LPR} = 1.67$ m length, B_B width = 2.76 m, $Z_B = 1.944$ m, Anti-Slamming bulbous bow length $P = 11.73$ m, and height $H = 1.20$ m.

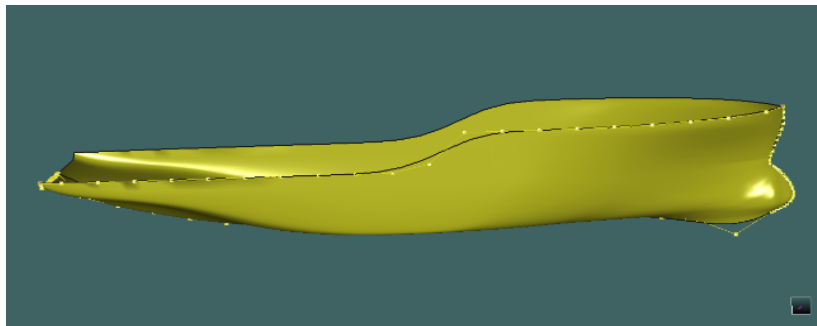

Figure 7. 3D Model of Delta type Bulbous Bow Δ

After we get a ship model with a variation of Anti-Slamming Bulbous Bow height, then we will get each displacement of each ship model. This displacement is then used for validation of the initial model. Displacement is expected to be worth 3003 tons or at least close to that value, with an error tolerance of less than 5%. Based on the results of ship modeling the displacement is obtained as follows

Table 3. Displacement Validation

No	Type model of <i>Bulbous Bow</i>	Displacement (ton)	Error %
1	Nabla V	3003	0
2	Oval O.	3003	0
3	<i>Delta</i> Δ	3003	0

3.1. Calculation of Ship Resistance

Obstacle analysis uses the Computational Fluid Dynamics (CFD) method with software, with the output produced as the total resistance (RT) of the ship. The analysis phase using CFD is as follows. The choice of the problem is taken in 3D, Fluid flow, Transpiration, the reason for choosing 3D is because the model analysis process will be carried out in the form of a model in the form of a three-dimensional ship. Fluid flow is chosen because the analysis of the model is carried out in fluid flowing, and Transpiration is chosen because the model analysed in the fluid flow has immersed parts and free surfaces.

After the meshing and meshing setup process, then proceed with the stage of the process of calculation (running) carried out in the form of iteration and calculation analysis on Tydn.

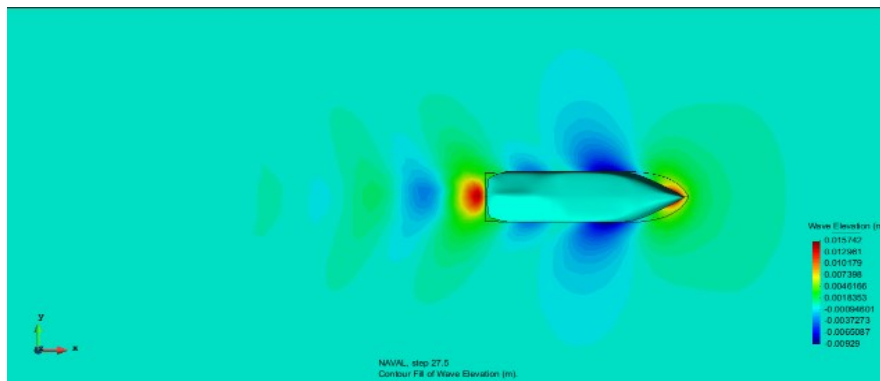

Figure 8. Display wave contours on the original model at Fr 0.297

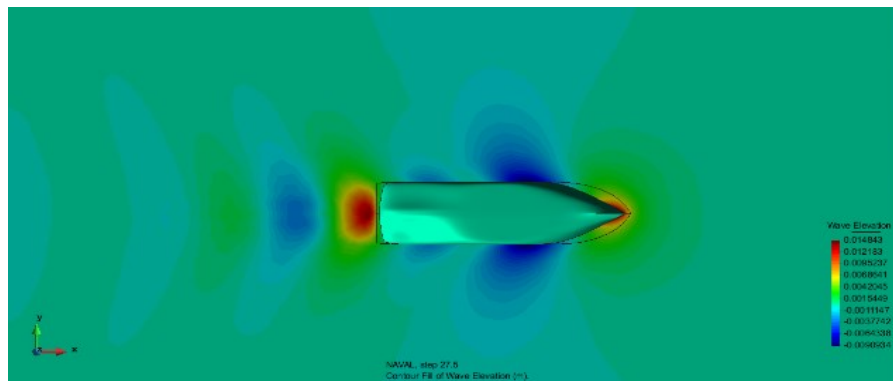

Figure 9. Display of wave contours in model V at Fr 0.297

Calculation of ship resistance using the Computational Fluid Dynamic method on the post-processor (running results) is taken from the results stage. Then from the data, we process it, so it becomes mature data. Calculation of the total resistance of the original ship with variations in the shape of the Bulbous Bow with Anti-Slamm Bulbous Bow is presented in the following table and figure

Table 4. Comparison of total ship resistance (R_T) without anti-slamm bulbous bow and anti-slamm bulbous bow using software

Fr	Total Resistance (R_T) N			
	Ship Model			
	Original	Nabla V	Oval O	Delta Δ
0,127	93	131	137	115
0,170	165	195	203	186
0,212	289	307	319	297
0,244	406	392	406	385
0,265	504	489	498	487
0,297	665	625	652	605

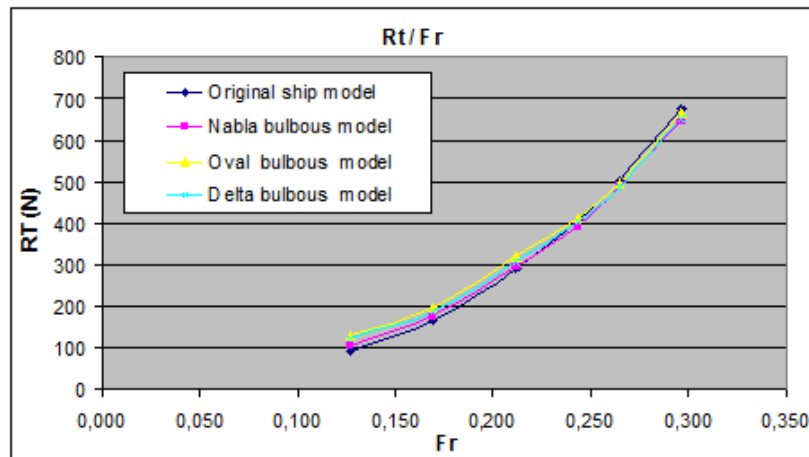

Figure 10. Chart of ship resistance values of ships without Anti-Slamming Bulbous Bow and Anti-Slamming Bulbous Bow with Froude Number (Fr).

The value of ship resistance with the addition of anti-slamming bulbous bow adds resistance to ships at low speeds. Whereas with increasing ship speed, ship resistance with anti-slamming bulbous bow rate of change of resistance decreases. At some point, the ship's resistance is more compared to ships without an anti-slamming bulbous bow

Table 5 Comparison of total drag coefficient (CT) model of the ship without anti-slamming bulbous bow and anti-slamming bulbous bow with the

Fr	Resistance Coefficient (CT) N			
	Ship Model			
	Original	Nabla V	Oval O	Delta Δ
0,127	0,1160	0,1466	0,1559	0,1421
0,170	0,1417	0,1555	0,1601	0,1534
0,212	0,1652	0,1677	0,1695	0,1653
0,244	0,1824	0,1789	0,1816	0,1758
0,265	0,1916	0,1858	0,1895	0,1817
0,297	0,2112	0,1967	0,2050	0,1902

speed of the boat Froude number Fr

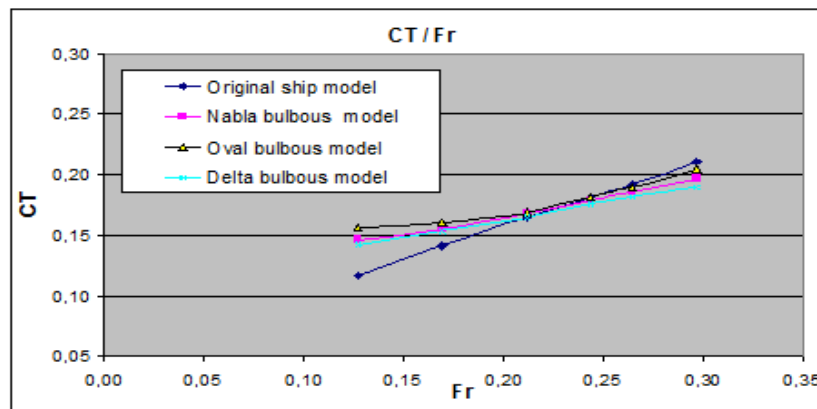

Figure 11. Graph of total resistance coefficient value of ships (CT) models of ships without Anti-Slamming Bulbous Bow and Anti-Slamming Bulbous Bow with the speed of the ship Froude Number (Fr).

The value of the ship's drag coefficient with the addition of anti-slamming bulbous bow increases with Fr. At a certain speed, the CT value is lower than that of a ship without the bulbous bow. This is due to reduced gastric friction with the water.

Table 6. Comparison of the coefficient of friction resistance (Cv) of the ship model without anti-slamming bulbous bow and anti-slamming bulbous bow with the speed of the boat Froude number Fr

Fr	Friction Coefficient (Cv) N			
	Ship Model			
	Original	Nabla V	Oval O	Delta Δ
0,127	0,006980	0,006480	0,006416	0,006590
0,170	0,006565	0,006242	0,006194	0,006335
0,212	0,006173	0,006069	0,005988	0,006141
0,244	0,005865	0,005944	0,005856	0,006014
0,265	0,005699	0,005863	0,005802	0,005971
0,297	0,005530	0,005881	0,005783	0,005955

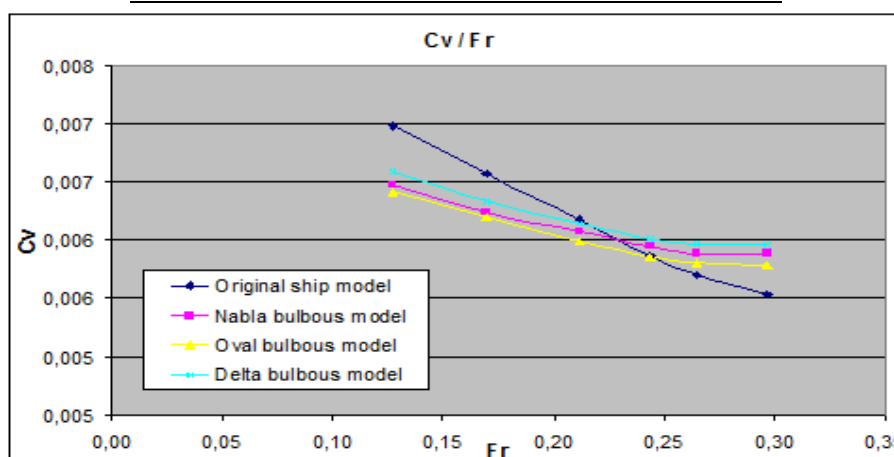

Table 7. The graph of the coefficient of friction resistance (Cv) of the ship model without Anti-Slamming Bulbous Bow and Anti-Slamming Bulbous Bow with the speed of the ship Froude Number (Fr).

The coefficient of ship's friction coefficient with the addition of anti-slamming bulbous bow decreases with an increasing number of Fr. At a certain speed, the CV value is lower than that of a ship without the bulbous bow; with increasing speed, the Reynolds number increases, so the boundary layer gets smaller.

Table 8. Comparison of wave resistance coefficient (C_w) model of the ship without anti-slamming bulbous bow and anti-slamming bulbous bow with the speed of the boat Froud number Fr

Fr	Wave Coefficient (C_w) N			
	Ship Model			
	Original	Nabla V	Oval O	Delta Δ
0,127	0,012861	0,011263	0,013210	0,011095
0,170	0,013334	0,011381	0,013387	0,011210
0,212	0,013932	0,011762	0,013736	0,011575
0,244	0,014791	0,012132	0,014017	0,011930
0,265	0,015445	0,012431	0,014330	0,012271
0,297	0,016587	0,013283	0,014792	0,012913

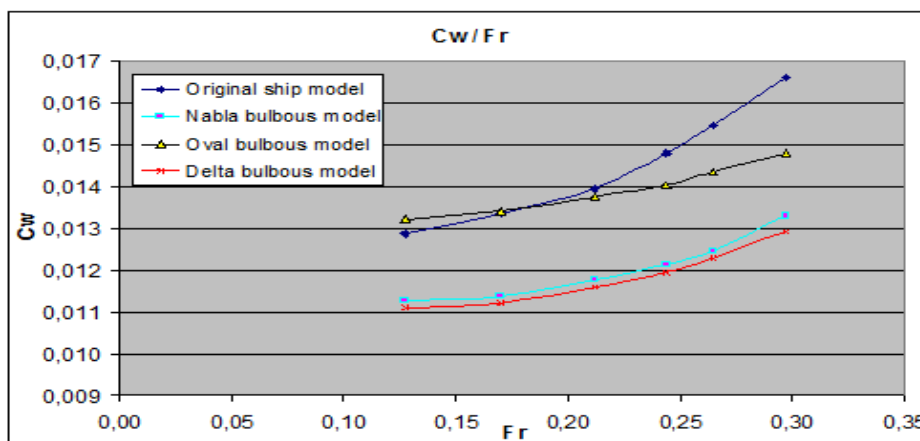

Figure 12. Graph of wave resistance coefficient (C_w) model of the ship without Anti-Slamming Bulbous Bow and Anti-Slamming Bulbous Bow with the speed of the boat Froud Number (Fr).

The value of the wave resistance coefficient with the addition of anti-slamming bulbous bow along with increasing the number Fr increases. At a certain speed, the value of CW is lower compared to ships without the bulbous bow. With increasing speed results in the ability to withstand waves getting smaller. From the table and figure above, it shows that supply ships (anchor handling tug supply / AHTS) that use Delta slamming bulbous bow models (Δ -Type) have the smallest obstacle compared to ships that do not use anti-slamming bulbous bow of 3,75%. From the picture above it can also be seen that the value of Cv (viscous coefficient) is inversely proportional to the value of Cw (wave coefficient) as a Froude number function between 0.127 to 0.297, so you can make a bulbous bow work area according to the graph above, which is around the Froude number (Fr) 0.20 or at a speed of 10.0 knots.

4. Conclusion

Based on the analysis that has been done, the effect of the anti-slamming bulbous bow on the total resistance value of the ship without an anti-slamming bulbous bow is reduced by 3.75%. The ship model with the use of anti-slamming bulbous bow which has the smallest total resistance is the ship with the form of anti-slimming bulbous bow type Delta (Δ - Type)

References

- [1] J. McCarthy, 1961. "The calculation of thrust and torque fluctuations of propellers in nonuniform wake flow," *Sens Actuator, B*, vol. **161**, pp. 80–7
- [2] S. Anggara 2013 *Evaluasi CFD Hambatan Lambung Katamaran Simetris dengan Variasi Konfigurasi Ukuran Bulbous Bow Tipe Goose Neck*, *J. Tek. Perkapalan*, pp. 1–8
- [3] R. Bhattacharyya 2012 *Dynamic of Marine Vehicles*. New York, United States of America, 1972.
- [4] I. Darmawan, E. Djatmiko, and M. B. Murtedjo, *Analisa Slamming Offshore Patrol Boat*. *J. Tek. POMITS*, vol. **1**, pp. 1–6
- [5] A. M. Kracht 1978 *Design of Bulbous Bow*, *SNAME Trans.*, vol. **86**, pp. 197–217
- [6] F. Azmi 2016 *Analisa Pengaruh Anti-Slamming Bulbous Bow Terhadap Hambatan dan Olah Gerak Kapal Anchor Handling Tug Supply (AHTS) Menggunakan CFD*, *J. Tek. Perkapalan*, pp. 1–10
- [7] M. Ventura 2003 *Bulbous Bow Design and Construction*
- [8] S. A. Harvald 1983 *Resistance and propulsion of ships*
- [9] A. F. Molland, J. F. Wellicome, and P. R. Couser 1996 *Resistance experiments on a systematic series of high speed catamaran forms: Variation of length-displacement ratio and breadth-draught ratio* *Trans. RINA*, vol. **138**. pp. 59–71
- [10] C. B. Barrass 2004 *Ship Design and Performance for Masters and Mates*
- [11] Murdijanto, K. A. P. Utama, and A. Jamaluddin 2011 *An Investigation Into the Resistance/Powering and Seakeeping Characteristics of River Catamaran and Trimaran*, *Makara Seri Teknol.*, vol. **15**, no. 1, pp. 25–30