

# Mobile Measurement System of Ozone Concentration in Urban Areas

Suryono Suryono  
Department of Physics,  
Diponegoro University,  
Semarang, Indonesia 50273  
e-mail: suryono@fisika.undip.ac.id

Ainie Khuriati  
Department of Physics,  
Diponegoro University,  
Semarang, Indonesia 50273  
E-mail: ainiekhuriati@fisika.undip.ac.id

**Abstract** - Ozone concentration significantly affects life quality of the people in an area. Ozone concentration that exceeds certain thresholds in heavily populated areas like most cities may be harmful for health and can even cause death. However, ozone monitoring has only so far been carried out at fixed sampling points using stationary instruments or conducted with manual recording instruments at certain sampling points. These types of measurements cannot represent the whole suburban areas that tend to be wide and populous. This paper proposes a mobile model of measuring ozone concentration with the integration of ozone sensors and Global Positioning System (GPS) sensor circuit. Measured data are acquired by the microprocessor, saved in a data base and analysis results are linked to a web mapping service. Measurements are carried out by encircling the intended urban areas. Results show that data from ozone sensors and measurement coordinates (latitude and longitude) can be stored in the data base and can visually be observed on the web mapping service in the form of spatial distribution of measurement points. Quantities of ozone concentration measurement results for a wide area can be seen on the data base. The system developed here is capable of monitoring environmental condition by acquiring ozone concentration distribution values.

**Keywords** — concentration, measurement, mobile model, web mapping service, environment condition

## I. INTRODUCTION

Ozone is one of the gases that determine the quality of our environment and it affects our health. The ozone layer in the atmosphere filters ultraviolet light that negative effects for life on Earth can be eliminated. At doses exceeding certain levels, rays from the space may cause harmful diseases. Hence, the thinning out of ozone layer poses threat to life. This knowledge of the importance of the ozone layer helps to determine anticipatory measures to prevent the dangers the ozone may cause [1]. Specifically, the ozone layer protects life on Earth from the negative effects of ultraviolet rays that may cause diseases such as cancer and cataract, and damages to plants, and also marine biota [2].

Hence, destruction of the ozone layer certainly poses threat to humankind. The major cause of ozone layer destruction is industrial activities that result in gases interacting with ozone and destroying its molecular bonds. Another cause

is the greenhouse effect [3]. Improper concentration of ozone in the environment affects life in it. The ozone for example, is an important parameter of water quality, and hence, measurement of ozone concentration is paramount in maintaining water quality.

High concentration of ozone above the safe threshold is also detrimental to health, from causing lung disorders to leading to death. Therefore, there needs to be a deregulation for the measurement of ambient air quality standard [4,5]. Some earlier researches suggest a correlation between ozone concentrations in the environment and cases of deaths [6]. Ozone from environmental sources may enter rooms via ventilations [7]. That is why, a system of ozone concentration monitoring and evaluation is very much required.

Activities by people in a heavily populated area in the suburbs demand measurement of ozone concentration of more than just at one central point. This kind of measurement needs an adequate spatial sampling that in turn requires a significant number of instruments. On the other hand, measurement instruments for the ozone layer are quite expensive and are still immobile and they also need expensive maintenance [8]. This is where engineering to devise an affordable ozone concentration measurement instrument to be used in wide areas with significant number of population comes in [9].

Most quantifications of ozone concentration in an area need modeling and there are uncertainties on prediction results [10]. Modeling of ozone concentration in an area is also challenging due to the complexity of input elements that are probabilistic in nature. However, global measurements for extremely large area spans have been carried out with the help of satellites [11]. Nonetheless, the drawbacks for these include expensive costs and measurement spatial coordinates. At the local level, measurements of ozone concentration in the environment are conducted manually in one location and involve optical instruments [12]. This type of measurement does not support online data acquisition.

This research proposes a mobile model of ambient ozone concentration measurement system. The measurement model here is very cheap as it only involves an ozone sensor data acquisition system that is integrated with a Global Positioning System (GPS) sensor. The use of GPS for measurement merits new contribution to the measurement method. Measurement system using positional data allows the monitoring of spatial

conditions. This type of system has been widely developed for monitoring of the weather, the environment, health, and the likes [13, 14]. The system here is developed using a wireless sensor system (WSS) that allows data in the field to be sent via internet network [15]. The use of sensors for measurement automation has provided higher economic efficiency and accuracy.

## II. INSTRUMENT DESIGN AND REALIZATION

### 2.1 Ozone Sensor Circuit

The ozone is a blue gas with odor that is denoted as  $O_3$ . It is formed by a chemical reaction in the space with breaking down and combination of  $O_2$  molecules into ozone. This kind of reaction also occurs in industrial areas due to the use of gas and also the greenhouse effect. Ozone forming reaction is shown in Fig. 1.

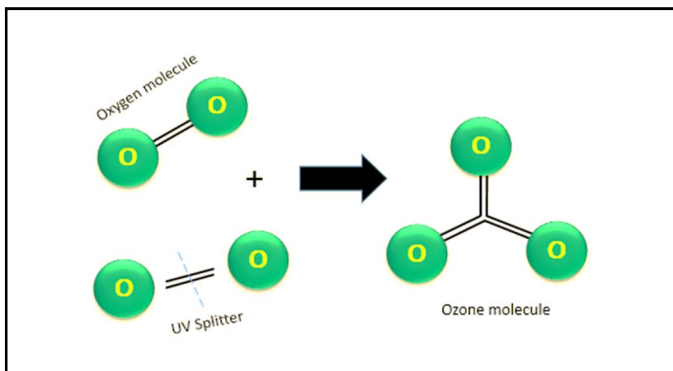

Fig. 1. Chemical reaction resulting in ozone formation.

Ozone sensors can be developed from semiconductor materials. These sensors alter  $O_3$  concentration into electrical parameter of voltage. One of the semiconductors used in making sensors is the  $SnO_2$  metal oxide. Construction of a semiconductor type ozone sensor is given in Fig. 2.

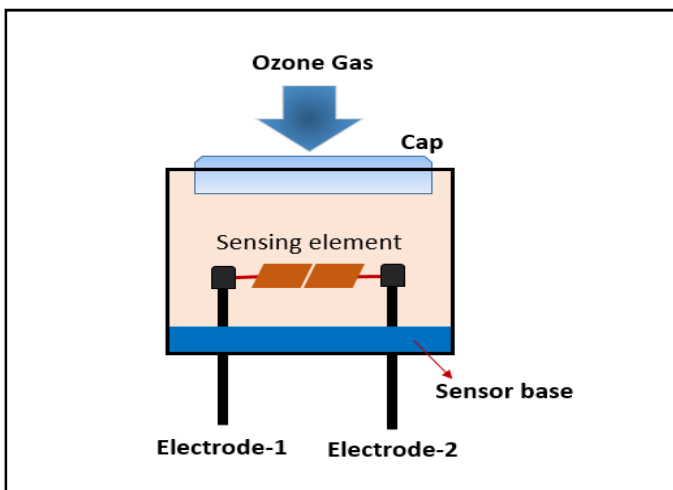

Fig. 2. Construction of an ozone sensor.

An ozone sensor consists of a semiconductor element, a sensor cap, a sensor base, and electrodes. This type of sensor works at high temperatures that it requires heating elements around the sensor elements. The ozone around sensor elements is absorbed and ionized that negative ions builds up inside the sensor elements. At the same time, on the surface of the  $SnO_2$  are donor electrons that bind the ozone ions and result in positive ions in the layers. This process yields surface potential energy that stalls velocity. Electronically, this process creates a potential barrier that stalls the electron velocity. In order to make an ozone sensor, both  $SnO_2$  electrodes are connected to a power supply that allows electricity that flows in the sensor elements to correlate with ozone concentration in their surroundings. A circuit of a  $SnO_2$  semiconductor type ozone sensor is depicted in Fig. 3. The  $R_L$  resistor is installed parallel to the sensor element in order to yield output voltage  $V_{RL}$ , which is a multiplication between the current flowing in sensor element and  $R_L$ . Hence, the relationship between ozone and voltage  $V_{RL}$ .

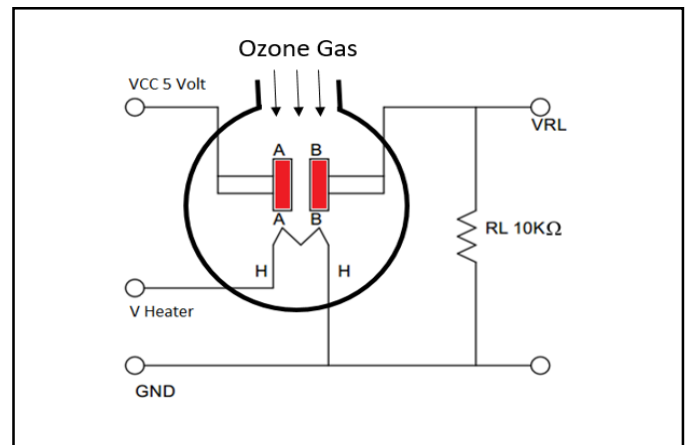

Fig. 3. Construction and circuit of an ozone sensor.

### 2.2 Global Positioning System (GPS) Sensor Circuit

Global Positioning System (GPS) is an electronic instrument used to determine the position of latitude and longitude. This position results from geometrical comparison between the distance of detected point and standard station on Earth against the distance of points detected by satellite. This research employs the GPS Ublox NEO-6M GPS module and GY-GPS6MV2 NEO6MV2 module, which are capable of Time-To-First-Fix (TTFF) acquisition in less than 1 second, massive parallel frequency search, electronic interference damping, and come with an anti-multi path effect. Architecture of the GPS used in this research is shown in Fig. 4.

The GPS Neo-6M sensor consists of an antennae and an RF satellite signal receiver, and a base band processor that functions to process GPS signal, and also an interfacing device equipped with external microprocessor. Reading of GPS coordinates can be carried out by a serial communication

system using the Universal Asynchronous Receiver/Transmitter (UART) protocol. Instructions for reading of GPS coordinates are sent via an RxD pin, and the resulting coordinate data acquisition is received by an external Oleg processor via the TxD pin. Important variables in GPS are latitude and longitude, each with different instructions. Microcontroller ESP-8266 is used to read both parameters. This microcontroller is so effective because it has small dimension and is equipped with USB serial communication system that allows it to transfer data to the other devices.

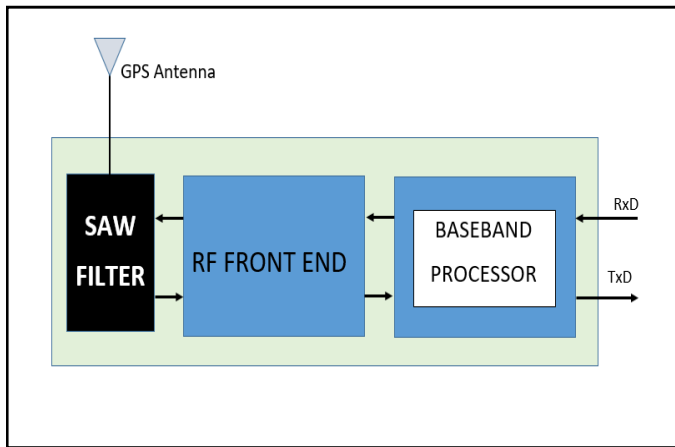

Fig. 4. Architecture of GPS module.

### 2.3 Data Acquisition System

There are two instruments playing important roles in gathering data in this research. They are the ozone sensor and the GPS receiver. Units as output from both sensors are acquired and stored in the data base system. Therefore, microprocessor is used in the data acquisition system to store data from readings of the ozone sensor, and latitude and longitude from the GPS. The main function of microcontroller ESP-8266 is to convert ozone analog data into digital data, to instruct GPS reading, and to serve as interface from data to microprocessor. Diagram of data acquisition system for ozone concentration using the mobile measurement model is given in Fig. 5.

The ozone sensor yields analog signal correlating to gas concentration. This output signal is converted into digital data by the ADC0 of microcontroller ESP-8266. Resulting digital values altered using sensor characteristics formula that shows the relationship between gas concentration and output voltage. Scripts of this formula and the other data acquisition programming are written in the microcontroller ESP-8622 with C language. GPS sensor is connected to ESP-8266 serial pin, and the RxD GPS pin is connected to TxD pin of microcontroller ESP-8266. This also applies for the TxD GPS pin, which is connected to the RxD microcontroller pin. Instructions for reading of latitude and longitude are also written in the ESP-8622 microcontroller. Then sequentially, data from reading of ozone and GPS sensors are sent to the microprocessor.

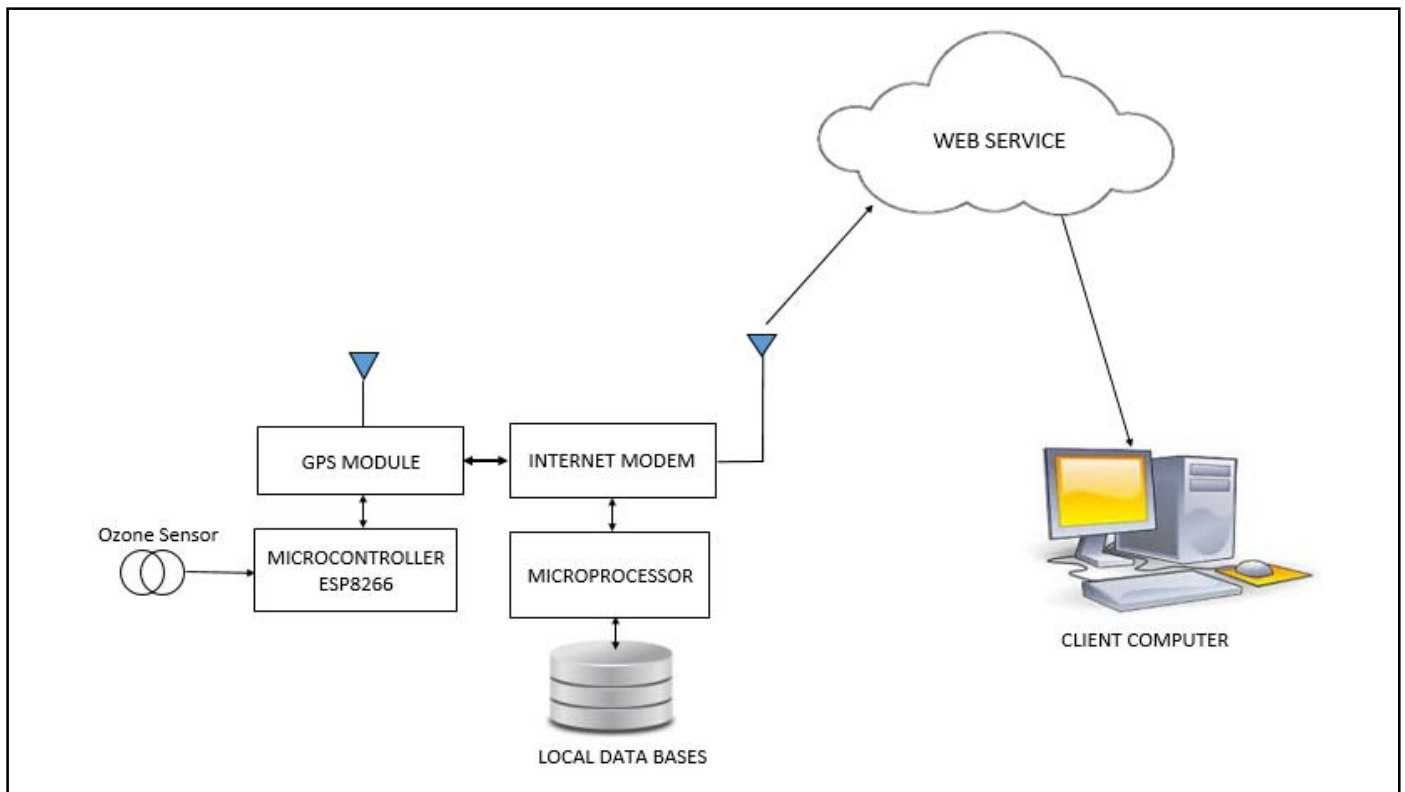

Fig. 5. Diagram of mobile data acquisition system for ozone concentration.

The microprocessor used in this research has specifications 64-bit, 2.25 GHz execution speed, 2 GB Ram, and a USB port for internet connection using modem and a solid state disk of 64 GB capacity. All those features are integrated in a system-on-chip that allows for lower electrical consumption and better fit for data acquisition in the field. An operating system is also installed in the microprocessor, along with a data acquisition program, as well as data base to store data of time, ozone concentration, and latitude and longitude coordinates. Other than those functions, the microprocessor is also used to connect with the web mapping services.

### III. RESULT AND DISCUSSION

The mobile model of data acquisition system for ozone concentration developed here is mounted on a car. Sensor units and GPS antennae are mounted outside the cabin, while the data acquisition system is installed inside the car. This paper focuses on the aspects of data acquisition and data communication. Meanwhile, ozone sensor characterization refers to earlier researches.

Spatial characteristics of the GPS receiver are tested to compare acquired coordinates covered during field measurement. Measurements are made as the car stops as to prevent errors due to delay time in data transmission by the GPS receiver. Accuracy position measurement values using GPS are calculated based on the mean absolute percentage error (MAPE) formula:

$$MAPE = \left| \frac{C_s - C_m}{C_m} \right| \times 100\% \quad (1)$$

Where,  $C_s$  is the coordinate standard which by using google map and  $C_m$  is the coordinate value read on the GPS sensor. This is an example of MAPE calculation at a point measurement coordinate that has been obtained at a location:

$$MAPE = \left| \frac{7.054886724 - 7.054646232}{7.054886724} \right| \times 100\% \\ = 0.024\%$$

Table 1 shows the MAPE measurement results of the acquired GPS module acquisition. The figures presented are the coordinate values of some points taken as test samples. The calculations are performed on both Latitude and Longitude coordinates. Each coordinate measurement point in the GPS Module is always compared to the latitude and longitude values in the google map obtained online. From the calculation that has been done obtained MAPE average value of 0.0024%. From these values it can be seen that the GPS coordinate reading system can work accurately.

TABLE 1. MAPE MEASUREMENT RESULTS OF THE ACQUIRED GPS MODULE ACQUISITION.

Measured Coordinate	Reference Coordinate	MAPE (%)
7.054646232	7.054886724	0.0341
7.055862852	7.055802822	0.0009
7.055757062	7.055952067	0.0028
7.053415872	7.053866856	0.0064
7.053178924	7.053735262	0.0079
110.4353177	110.4354706	0.0001
110.4372446	110.4382172	0.0009
110.4398397	110.4393234	0.0005
110.4398663	110.4394684	0.0003
110.4322753	110.4326889	0.0004
Average		0.0024

Acquired data by this system are evident in the form of data of time, ozone concentration and latitude and longitude of measurement points. These data can be downloaded from the data base stored in the solid state disk of the microprocessor. The data base is equipped with connection to web mapping services, in that each position from data reading can be pointed out by looking at the address link in google map. Table 2 shows the results of ozone sensor data acquisition along with coordinate values at measurement points.

TABLE 2. RESULT OF OZONE DATA MEASUREMENT WITH COORDINATE VALUE.

Latitude	Longitude	Ozone Concentration (ppm)
-7.704853482	110.4402081	0.432
-7.049653048	110.4406279	0.422
-7.049986832	110.4418612	0.214
-7.050455082	110.4415583	0.318
-7.051571851	110.4414142	0.467
-7.051153173	110.4441292	0.322
-7.048342231	110.4452058	0.544
-7.046223163	110.4423142	0.343
-7.046285151	110.4409247	0.326
-7.046714791	110.4394979	0.413
-7.054025175	110.4356758	0.233
-7.055802837	110.4382176	0.312
-7.050948144	110.4390431	0.278
-7.049499972	110.4399564	0.132
-7.048679740	110.4406128	0.229
Average		0.325

These addresses are simultaneously recorded during acquisition of latitude and longitude coordinates. Address links are stored in the form of data string that is inserted in the latitude and longitude data. Data recorded in the data base are plotted to

all measurement points that are connected to the web mapping services. Results of plotting for ozone concentration measurements in the research area are shown in Fig. 6. Results show that ozone concentration in the research area is 0.325 ppm

on average, with distribution range of 0.132 ppm to 0.544 ppm. The lowest and highest values from measurements can visibly be seen on the map. Hence, the system developed here eases integrative analyses of air quality condition in the environment.



Fig. 6. Plotting results of ozone measurement in the research area.

#### IV. CONCLUSION

Integration of ozone sensor and GPS receiver has proven to be effective in carrying out mobile measurement of ozone concentration in urban areas. Measurements covering large urban areas can be effectively carried out by mounting the mobile instrument developed in this research in vehicles such as cars. Ozone measurement data in an urban area can be acquired by creating a mobile concentration measurement system that is also capable of recording coordinates of measurement points with the help of a GPS receiver. Acquired data are stored in the data base that is connected online to web mapping services. Measurement results also reveal visual spatial distribution of measurement points involved. Quantities of measurement results can easily be found on the data base created. The system developed here is capable of monitoring environmental condition by acquiring ozone concentration distribution values.

#### REFERENCES

- [1] C. Dilek, and A. Zeynep, "Determination of pre-service elementary science teachers knowledge level about ozone layer", *Procedia*, Vol. 15, pp. 1438-1444, 2011.
- [2] N. J. Thines, L. A. Shipley., J. H. Basbman, J.R. Sludder, and W. Gao, "UV-B effects on the nutritional chemistry of plants and the responses of a mammalian herbivore", *Oecologia*, Vol. 156, pp. 125-135, 2008.
- [3] O. Bozkurt, and M. Aydo, "Ozon Tabakasi ve Görevleri", *Kastamonu Egitim Dergisi*, Vol. 12(2), pp. 369-376, 2004.
- [4] M. Hyttinen., P. Pasanen, and P. Kalliokoski, "Removal of ozone on clean, dusty and sooty supply air filters", *Atmos. Environ.* Vol. 40 (2), pp. 315-325, 2006.



- [5] M. Lippmann, "Health effects of ozone a critical review", *JAPCA*, Vol. 39 (5), pp. 672-695, 1989.
- [6] K. Beven, and J. Freer, "Equifinality, data assimilation, and uncertainty estimation in mechanistic modeling of complex environmental systems using the GLUE methodology", *J. Hydrol.* Vol. 249, pp. 11-29, 2001.
- [7] L. Dayi, K. Panagiota, and C. Qingyan, "Study of Outdoor Ozone Penetration into Buildings through Ventilation and Infiltration", *Building and Environment*. 2015.
- [8] L Gui, T. Val, A. Wei, and R. Dalce, "Improvement of range-free localization technology by a novel dv-hop protocol in wireless sensor networks", *Ad Hoc Networks*, Vol. 24, pp. 55-73, 2015.
- [9] D. E. Williams, J. Salmond, Y. F. Yung, J. Akaji, B. Wright, J. Wilson, G. S. Henshaw, D. B. Wells, G. Ding, J. Wagner, and G. Laing, "Development of Low-Cost Ozone and Nitrogen Dioxide Measurement Instruments Suitable for Use in an Air Quality Monitoring Network", *IEEE Sensor Conference*, pp. 1099 – 1104, 2009.
- [10] G. D. Ricard, D.P David, E. G. Ian, S. S. David, M. D Ruth, N. Vaishali and J.Y. Paul, "Uncertainties in models of tropospheric ozone based on Monte Carlo analysis: Tropospheric ozone burdens, atmospheric lifetimes and surface distribution", *Atmospheric Environment*, Vol. 180, pp. 93-102, 2018.
- [11] H. Sachiko, K Mizuo, D. Makoto, T. S. Tsuyoshi and L. Xiong, "Seasonality of the lower tropospheric ozone over China observed by the Ozone Monitoring Instrument", *Atmospheric Environment*. Vol. 184, pp. 244-253, 2018.
- [12] J. Kuttippurath, P. Kumar, P.J Nair and A. Chakraborty, "Accuracy of satellite total column ozone measurement in polar vortex conditions: Comparison with ground-based observation in 1979-2013", *Remote Sensing of Environment*. Vol. 209, pp. 648-659, 2018.
- [13] N. Jakowski, V. Wiken, and C. Mayer, "Space weather monitoring by GPS measurement on board CHAMP", *IEEE*, 2017.
- [14] Y. Hongwei, and J. Yi, "Maximum likelihood network localization using range estimation and GPS measurements", *IEEE*. 2017.
- [15] C. Jun, Y.U. Sun-Zheng, and L. Jing-li., "The design of a wireless data acquisition and transmission system", *Journal of Networks*, Vol. 4. No. 10, pp. 1042-1049, 2009.