

Performance Investigation of High Throughput WLAN 802.11n by Receiver Diversity and Antenna Spacing

Wahyul Amien Syafei

Electrical Engineering, Faculty of Engineering, Diponegoro University
Prof. H. Soedarto, SH, Tembalang Campus, Semarang, Indonesia
wasyafei@undip.ac.id

Abstract— The high throughput WLAN 802.11n exploits Multiple Input Multiple Output antenna to provide high throughput and high performance. It transmits the data into spatial streams to be more robust to multipath fading propagation environment. In this paper the performance of WLAN 802.11n is investigated by combining receiver diversity technique and antenna spacing on both transmitter and receiver. Configuration of 2×2 to 2×8 and 4×4 to 4×8 MIMO antennas with spacing varied every $\lambda/4$ between $\lambda/4$ to 2λ are investigated under in-door channel model. The more receiver antenna, the probability of signal fading is less, the better the performance is. The farther space between antennas, the lower the correlation and interference, the better the performance is with the cost of wider size of hardware.

Keywords—WLAN 802.11n; MIMO; Receiver diversity; Antenna Spacing

I. INTRODUCTION

The upcoming WLAN IEEE802.11n is able to provide high throughput up to 600 Mbps. This WLAN system employs Multiple-Input Multiple-Output (MIMO). MIMO is a promising technique to improve channel capacity and obtain high throughput by using multiple antennas on both transmitter and receiver. It separates the transmitting data into some spatial streams without requiring additional bandwidth. [1]

The performance of wireless communications is always degraded by multipath fading. MIMO is implemented to solve this problem by exploiting spatial diversity techniques in receiver. One of techniques to combine the diversity branches at the receiver is a maximum ratio combiner (MRC). It gives the highest antenna diversity gain among others. [2, 3, 4]

MIMO involves some adjacent antennas. Adjusting the space between antenna impacts their correlation. The closer space between antennas, the higher their correlation which lead to higher interferences. [5]

In order to enhance the performance, in this paper the performance of WLAN 802.11n is investigated by exploiting the MIMO it self. Antenna configuration of 2×2 to 2×8 , 3×3 to 3×8 , and 4×4 to 4×8 is combined with

adjusting the space between antennas on both transmitter and receiver. Simulation is conducted under model channel B of IEEE802.11 TGN to represent small office environment [6]. The trade - off between number of receive antennas, space between antennas, and hardware size determines the desired performance.

The rest of this paper is organized as follows. In Chapter II the MIMO receive diversity, channel capacity, and antenna correlation in WLAN IEEE802.11n are briefly reviewed. Chapter III contains the scenario of the observed system and the parameters of simulation, Chapter IV presents the analysis of simulation's results, and conclusion is drawn in Chapter V.

II. MIMO AND WLAN 802.11N

A. Receiver Diversity

In general, additional receive antennas can be added to the receiver in order to increase the diversity gain. This principle also applies to a MIMO receiver which is implemented in WLAN 802.11n. If the receiver has more antennas than spatial streams (transmitted signal), the diversity order increases by the difference between the number of receive antennas and the number of transmitted spatial streams [3].

In the basic MIMO case the number of transmit antennas, spatial streams, and receive antennas are all equal. In receiver diversity case, for instance, there are two transmit antennas and spatial streams, but three receive antennas. [4].

In the diversity scenario, there are different combining schemes: Selection Diversity, Equal Gain Combining (EGC), and Maximum Ratio Combining (MRC). The simulation in this paper is based on Maximum Ratio Combining.

B. Maximum Ratio Combining

MRC is an appropriate antenna-combining strategy when the received signal is mainly impaired by noise. The MRC is similar to EGC except that the algorithm tries to optimally adjust both phases and gain of each element prior to combining. MRC achieves highest antenna diversity gain as compared with others [6].

Received signal of an $M \times N$ i.e. N receive antennas and M transmit antennas MIMO system is described as :

$$\mathbf{Y}_N = \sqrt{\frac{\rho}{M}} \cdot \mathbf{H}_{N \times M} \mathbf{X}_M + \mathbf{Z}_N \quad (1)$$

where \mathbf{X}_M is the transmitted data; $\mathbf{H}_{N \times M}$ is the MIMO channel fading matrix; \mathbf{Z}_N is additive white Gaussian noise (AWGN) defined as Normal (0,1); ρ is the average signal-to-noise ratio (SNR);

An MRC receiver is given as follows:

$$\begin{aligned} \mathbf{R} &= \mathbf{H}^H \mathbf{Y} \\ &= \sqrt{\frac{\rho}{M}} \cdot \mathbf{H}^H \mathbf{H} \mathbf{X} + \mathbf{H}^H \mathbf{Z} \end{aligned} \quad (2)$$

where \mathbf{H}^H is the Hermitian (complex conjugate transpose) of \mathbf{H} .

MRC output could also be defined by the weighted sum of the different fading paths or branches. Combining more than one branch signal requires co-phasing, where the phase θ_i of the i th branch is removed through the multiplication by $ai = ai e^{-j\theta_i}$ for some real-valued ai . This phase removal requires coherent detection of each branch to determine its phase θ_i . Without co-phasing, the branch signals would not add up coherently in the combiner, so the resulting output could still exhibit significant fading due to constructive and destructive addition of the signals in all the branches .

After MRC is applied, the received signal can be equalized as follows:

$$\begin{aligned} \tilde{\mathbf{X}} &= \sqrt{\frac{M}{\rho}} \cdot (\mathbf{H}^H \mathbf{H})^{-1} \mathbf{R} \\ &= \mathbf{X} + \sqrt{\frac{M}{\rho}} \cdot (\mathbf{H}^H \mathbf{H})^{-1} \mathbf{H}^H \mathbf{Z} \end{aligned} \quad (3)$$

C. Diversity gain

The effectiveness of diversity is usually presented in terms of *diversity gain* (DG). Diversity gain can be defined as the improvement in time-averaged signal-to-noise ratio (SNR) from combined signals from a diversity antenna system, relative to the SNR from one single antenna in the system, preferably the best one [7]. The diversity order indicate how the slope of average probability of error as a function of average SNR changes with diversity. The diversity order (D) of an $M \times N$ MIMO system can found as [8]:

$$D = N - M + 1 \quad (4)$$

When the diversity order D is connected with the average SNR of the combiner output, we obtain:

$$\begin{aligned} \bar{R} &= \int_0^{\infty} \rho p_R(\rho) d\rho \\ &= \int_0^{\infty} \frac{\rho D}{\bar{\rho}} \left[1 - e^{-\rho/\bar{\rho}} \right]^{D-1} e^{-\rho/\bar{\rho}} d\rho \\ &= \bar{\rho} \sum_{i=1}^D \frac{1}{i} \end{aligned} \quad (5)$$

where,

\bar{R} = average SNR from combiner output

ρ = Signal to Noise Ratio (SNR)

p_R = SNR distribution

From (5), it can be seen that the average SNR gain rises with M , but not linearly. The biggest gain is obtained by going from no diversity to two-branch diversity. Increasing the number of diversity branches from two to three will give less gain than going from one to two, and in general increasing M yields diminishing returns in terms of the SNR gain .

D. MIMO Channel Capacity

A. Channel capacity is maximal bit rate of data transmit that can be obtained for a given quality of received signal and usually expressed in units of bps/Hz.

For the case of one transmitting and one receiving antenna (SISO), the classical Shannon formula of channel capacity is given by

$$C = \log_2(1 + SNR) \text{ bps/Hz}^* \quad (6)$$

For an $M \times N$ MIMO system, it is well known that there is an increase in SNR and the increase in capacity depends on the transmitting power distribution between the different antennas. If the properties of propagation channel are unknown and having a symmetrical MIMO system, $M=N$, with a Gaussian Noise assumption, the capacity of the MIMO channel can be expressed by [3]:

$$C = \log_2 \left(I_n + \frac{\rho}{n} \cdot \mathbf{H} \mathbf{H}^H \right) \text{ bps/Hz} \quad (7)$$

where H is the normalized channel matrix and ρ is the mean received SNR in each of the n antennas. I_n is the identity matrix of dimension $(N \times N)$.

E. Antenna Correlation

Antenna correlation is applied to the random element X_{ij} to incorporate antenna correlation into channel model, as follows:

$$[X] = [R_{R_X}]^{1/2} [X] ([R_{T_X}]^{1/2})^T \quad (8)$$

where R_{R_X} and $R_{T_X}^*$ are receive and transmit correlation matrices. $[R]^{1/2}$ is defined as a matrix square root, where $[R]^{1/2} \cdot [R]^{1/2} = R$. X is an independent, complex Gaussian random variable with zero mean and unit variance. The correlation matrices, R_{R_X} and R_{T_X} are defined as follows [4]:

$$R_{T_X} = \begin{bmatrix} 1 & \rho_{T_{x12}} & \rho_{T_{x13}} & \rho_{T_{x14}} \\ \rho_{T_{x21}} & 1 & \rho_{T_{x23}} & \rho_{T_{x24}} \\ \rho_{T_{x31}} & \rho_{T_{x32}} & 1 & \rho_{T_{x34}} \\ \rho_{T_{x41}} & \rho_{T_{x42}} & \rho_{T_{x43}} & 1 \end{bmatrix}$$

$$R_{R_X} = \begin{bmatrix} 1 & \rho_{R_{x12}} & \rho_{R_{x13}} & \rho_{R_{x14}} \\ \rho_{R_{x21}} & 1 & \rho_{R_{x23}} & \rho_{R_{x24}} \\ \rho_{R_{x31}} & \rho_{R_{x32}} & 1 & \rho_{R_{x34}} \\ \rho_{R_{x41}} & \rho_{R_{x42}} & \rho_{R_{x43}} & 1 \end{bmatrix} \quad (9)$$

where $\rho_{T_{xij}}$ are the complex correlation coefficients between the i th and j th transmitting antennas, and $\rho_{R_{xij}}$ are the complex correlation between the i th and j th receiving antennas.

F. Correlation Coefficient

In an antenna system, the correlation coefficient is a parameter for channel quality. When the correlation coefficient is lower, the channel capacity will be higher. This is why we investigated the correlation coefficient between the antennas in 4x4 antenna system because the antenna spacing gives impact to correlation coefficient.

In the 802.11n channel model, a complex correlation coefficient is derived based on the power angular spectrum (PAS) formulation [4]. The PAS for each tap is a function of the angular spread (AS) and angle of incidence (angle of arrival (AoA) or angle of departure (AoD), depending on Tx or Rx) of each cluster, as shown in Fig. 1. The shape of the PAS distribution commonly used for 802.11n is truncated Laplacian. The PAS distribution over the angle for each tap is given by

$$PAS(\phi) = \frac{1}{A} \sum_{k=1}^{N_c} \frac{P_k}{v_k} \exp \left[-\frac{\sqrt{2} |\phi - \psi_k|}{v_k} \right] \quad (10)$$

where N_C is the number of clusters, and for each cluster k , P_k is the tap power, ψ_k is the tap AS, and ψ_k is the tap angle of incidence.

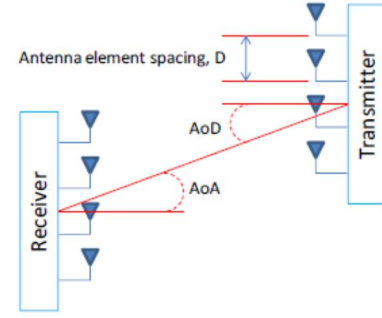

Fig.1 Angle of Arrival (AoA), Angle of Departure(AoD) and antenna spacing

For a uniform linear antenna array, the correlation of the fading between two antennas spaced D apart is described in [4]. The correlation functions are given in [6], as follows:

$$R_{XX}(D) = \int_{-\pi}^{\pi} \cos \left(\frac{2\pi D}{\lambda} \sin \phi \right) PAS(\phi) d\phi \quad (11)$$

$$R_{XY}(D) = \int_{-\pi}^{\pi} \sin \left(\frac{2\pi D}{\lambda} \sin \phi \right) PAS(\phi) d\phi \quad (12)$$

where R_{XX} is the correlation function between the real parts of the fading, R_{XY} is the correlation function between the real and imaginary parts of the fading, and λ is wavelength.

The complex correlation coefficient $\rho_{T_{xij}}$ between the i th and j th transmitting antennas, and $\rho_{R_{xij}}$ between the i th and j th receiving antennas is described by:

$$\rho = R_{XX}(D) + jR_{XY}(D) \quad (13)$$

G. The WLAN IEEE802.11n

The WLAN 802.11n promises to extend the reliability and throughput significantly. With MIMO technique it can provide a five-fold data rate increase with same 20 MHz bandwidth and a ten-fold data rate increase by doubling bandwidth to 40MHz. Therefore WLAN IEEE802.11n is called a High Throughput system. The WLAN IEEE802.11a/g can provide 54 Mbps in maximum data rate, while the IEEE802.11n device promises up to 600 Mbps.

Block diagram of transmitter and receiver of WLAN 802.11n are shown in fig.2 and fig.3. There are up to four antennas in both transmitter and receiver. However for investigation purposes, the antennas can be extended to eight. WLAN 802.11n set MCS to 31 to provide throughput up to 600 Mbps which is clearly described in table I. N_{ES} , N_{BPSCS} , N_{SD} , N_{SP} , N_{CBPS} , N_{DBPS} are number of encoding stream, number of coded bits per subcarrier, number of subcarrier data, number of subcarrier pilot, number of coded bits per OFDM symbol and number of data bits per OFDM symbol, respectively.

The data rate can be calculated by:

$$Data\ Rate = \frac{N_{DBPS}}{T_{GI} + T_{SYM}} \quad (14)$$

where $T_{sym} = 3.2 \mu s$ and T_{GI} normal and short are 800 ns and 400 ns, respectively.

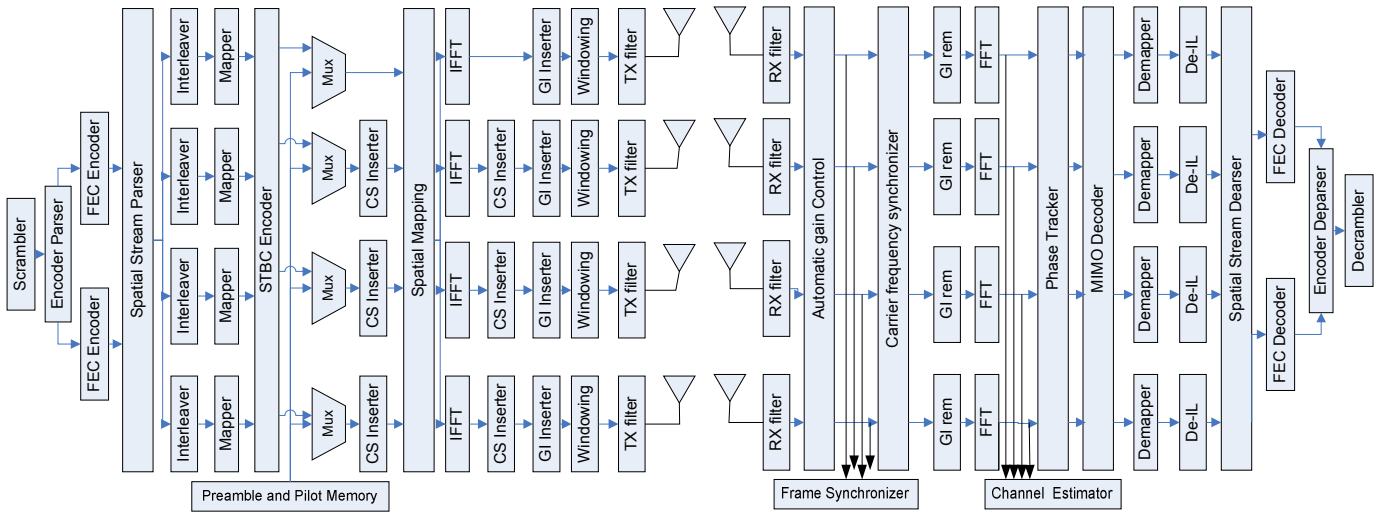

Fig.2 Block Diagram of transmitter IEEE 802.11n

Fig.3 Block Diagram of receiver IEEE 802.11n

TABLE I MCS SETTING DEFINES THE PARAMETERS OF THROUGHPUT

MCS	Modulation	R	N _{BPCS}	N _{SD}	N _{SP}	N _{CBPS}	N _{DBPS}	Data rate (Mbps)	
								Normal GI	Short GI
15	64 QAM	5/6	6	108	6	1296	1080	270	300
31	64 QAM	5/6	6	108	6	2592	2160	540	600

III. SIMULATION STAGE

This chapter explains the design of the system and simulation parameters that is used to evaluate this system. This simulation investigated 2x2 to 2x8, and 4x4 to 4x8 MIMO antennas system for both transmitter and receiver antenna side. The distance between the antennas were varied from $\lambda/4$, $\lambda/2$, $3/4 \lambda$, λ , $5/4 \lambda$, $3/2 \lambda$, $7/4 \lambda$, 2λ , where λ is the wavelength obtained from c/f (velocity of light/carrier frequency).

The other parameter is described in table II below

TABLE II SIMULATION PARAMETERS

Parameter	Value
Frequency Band	ISM: 5.25 GHz
Antenna Configuration	2x2 to 2x8, 4x4 to 4x8
Bandwidth	40 MHz
Channel Model	B of IEEE802.11 TGn
Number of Packet	1000
Length Packet	1000
GI Length	Normal
MCS	15 and 31
Antenna Spacing	$\lambda/4$, $\lambda/2$, $3/4 \lambda$, λ , $5/4 \lambda$, $3/2 \lambda$, $7/4 \lambda$, 2λ

IV. ANALYSIS

Test results on the MCS 15 can be seen in figure 4 with the target BER 10^{-4} , 2x2 antenna reaches the value at 29.75 dB, 27.5 dB antenna on the 2x3, 2x4 antenna at 26 dB, 24 dB on the 2x5 antenna, antenna 2x6 at 22.5 dB, 21.25 dB antenna on the 2x7, 2x8 antenna at 19.5 dB. The improvement from 2x2 to 2x3 antenna is 2.25 dB, 2x3 to 2x4 antenna is 1.5 dB, 2x4 to 2x5 antenna 2 dB, 2x5 to 2x6 antenna is 1.5 dB, 2x6 to 2x7 1.25, and 2x7 to 2x8 is 1.75 dB. The more receiver antennas the better performance is.

Simulation results of MCS 31 is shown in fig. 5 with target BER 10^{-4} , 4x4 antenna reaches the value at 35.75 dB, 29.5 dB antenna on the 4x5, 4x6 antenna at 27.25 dB, 26 dB antenna on the 4x7, and 4x8 antenna at 23.75 dB. Performance enhancement from 4x4 to 4x5 antenna is 6.25 dB, 4x5 to 4x6 antenna is 2.25 dB, 4x6 to 4x7 antenna is 1.25 dB, and 4x7 to 4x8 is 2.25 dB. Again, the higher the number of receiver antenna the better the performance is.

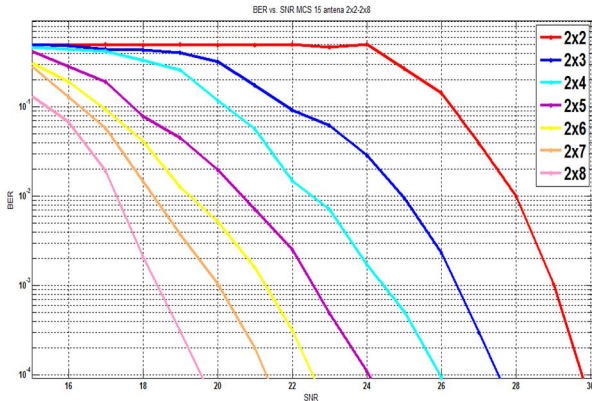

Fig.4 BER vs SNR of WLAN 802.11n MCS 15

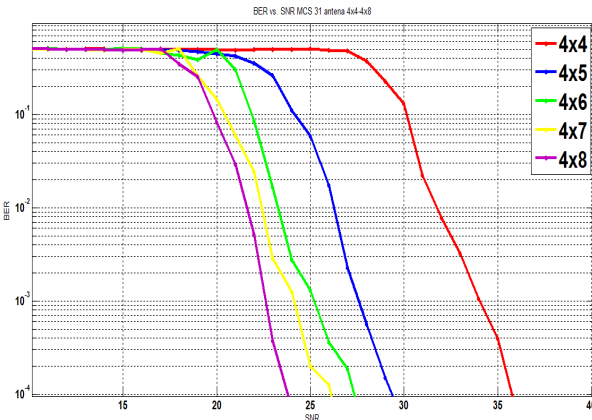

Fig.5 BER vs SNR of WLAN 802.11n MCS 31

Simulation results of MCS 31 is shown in fig. 5 with target BER 10^{-4} , 4x4 antenna reaches the value at 35.75 dB, 29.5 dB antenna on the 4x5, 4x6 antenna at 27.25 dB, 26 dB antenna on the 4x7, and 4x8 antenna at 23.75 dB. Performance enhancement from 4x4 to 4x5 antenna is 6.25 dB, 4x5 to 4x6 antenna is 2.25 dB, 4x6 to 4x7 antenna is 1.25 dB, and 4x7 to 4x8 is 2.25 dB. Again, the higher the number of receiver antenna the better the performance is.

In addition, the power savings is the most substantial going from no diversity to two-branch diversity, while diminishing returns as the number of branches is increased.

It can be proven from (4) that 2x3 configuration has second order diversity (D). From (5) with $D = 2$ (second order) to $D = 1$ have difference SNR combiner output (\bar{R}) larger than $D = 3$ to $D = 2$. This statement considers ρ as a constant.

WLAN 802.11n's performance as a MIMO system also determined by correlation coefficient between antennas. Antenna spacing shall give impact to correlation coefficient. Correlation coefficient will increase if antenna spacing is closer which can make higher interference.

Fig. 6 shows the investigation in 4x4 MIMO antenna system with antenna spacing varied from $\lambda/4$ to 2λ . For target BER 10^{-4} , 4x4 MIMO which spaced $0,25\lambda$ reach the value at 60 dB, 59.5 dB at a distance $0,5\lambda$, distance $0,75\lambda$ at 58.5 dB, 55.75 dB at a distance of 1λ , distance $1,25\lambda$ at

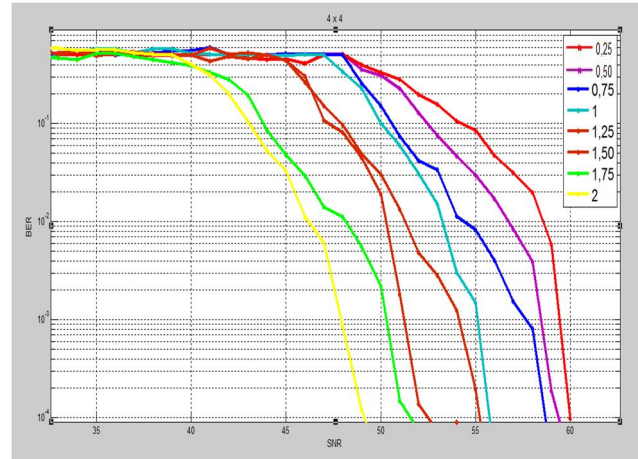

Fig. 6 BER Performance of WLAN IEEE 802.11n MCS 31 by varying the distance between antennas

55.25 dB, a distance of 1.5λ at 52.5 dB, a distance of 1.75λ at a distance of 51.5 dB and 49 dB at 2λ . The farther distance between antennas, the better the performance is. However, this shall require wider size of hardware.

V. CONCLUSION

In this paper we have investigated the performance of WLAN IEEE802.11n with receiver diversity and spacing between antennas. It is shown that the more the receive antennas, the less the probability of signal fading is, the better the performance is. Further, the performance also can be improved by increasing the space between antennas in both transmitter and receiver. The closer spacing of antennas, the higher correlation coefficient and give higher interference between antennas. Better performance is obtained by farther space but wider size of hardware is required. Trade-off between number of receive antennas, space between antennas, hardware size, and target BER should be considered carefully.

REFERENCES

- [1] "Draft STANDARD for Information Technology - Telecommunications and Information Exchange between Systems - Local and Metropolitan Area Networks - Specific Requirements", IEEE P802.11n/D9.0, March 2009.
- [2] E. Perahia and Robert Stacey, "Next Generation Wireless LANs-Throughput, Robustness, and Reliability in 802.11n". Cambridge University Press, 2008.
- [3] Wahyul Amien Syafei and Nuzulia, Gifina. "Performance Evaluation of WLAN IEEE 802.11n with Antenna Diversity for Two Transmitter". UAD, Jogiakarta, 2011. Indonesia.
- [4] G. J. Foschini and M. J. Gans, "On limits of wireless communication in a fading environment when using multiple antennas," Wireless Personal Communications., vol. 6, no. 3, pp. 311-335, March. 1998.
- [5] Wahyul Amien Syafei and Hayu Pratista. "Performance Evaluation of Wireless LAN IEEE802.11n by Antenna Spacing". International Conference on Information Technology and Electrical Engineering (ICITEE) 2011, Jogiakarta, Indonesia.
- [6] V. Erceg et al "Tgn Channel Models," doc.:IEEE 802.11-03/0940r4, 2003.
- [7] L. Schumacher, K.I. Pedersen and P.E. Mogensen, "From Antenna Spacing to Theoretical Capacities-Guidelines for Simulating MIMO System", The 13th IEEE International Symposium on Personal, Indoor and Mobile Radio Communications, 2002. Volume 2, 15-18 Sept. 2002 Page(s):587 - 592 vol.2.