

PAPER • OPEN ACCESS

Analysis of the effect of addition of stern flaps on the performance of 60 m fast boat

To cite this article: Parlindungan Manik *et al* 2021 *IOP Conf. Ser.: Mater. Sci. Eng.* **1034** 012032

View the [article online](#) for updates and enhancements.



ECS **240th ECS Meeting**
Digital Meeting, Oct 10-14, 2021
We are going fully digital!
Attendees register for free!
REGISTER NOW

Analysis of the effect of addition of stern flaps on the performance of 60 m fast boat

Parlindungan Manik*, Good Rindo, Hartono Yudo, Ebin Ezer Sinaga

Naval Architecture Department, Diponegoro University

Prof. Soedarto, Tembalang Campus, Semarang 50275, Indonesia

*Email: parlindunganmanik@lecturer.undip.ac.id

Abstract. Regulations from the International Maritime Organization (IMO) regarding energy efficiency mean that the ship design must have the least possible resistance so that fuel consumption is also low. Several modifications to the shape of the hull have been developed so that the performance of the ship can be improved so that its use is more efficient. The stern flap is a modification of the hull shape by adding an appendage to the lower transom. The application of the use of a stern flap can improve the movement of ships that are too heavy behind, causing the ship to have a tendency to trim the stern, increasing hydrodynamic work and reducing the obstacles that work while the ship is operating. This study analyzes the effect of adding an appendage to the stern in the form of a stern flap on the performance of fast boats using a computer program based on Computation Fluid Dynamic (CFD). This study was conducted by comparing the results of the analysis of the original model, namely without adding flaps with variations in the addition of flaps at the stern of the ship. Based on the analysis results, obtained an increase in ship performance for each stern flap variation compared to the original model. Flap V model with a flap length of 2% LPP and a Trailing Edge Down (TED) angle of 90 is the best variation. The total resistance value at each speed has a better decrease. Compared to other models, the total resistance of the ship is reduced by 5.53%.

Keywords: ship resistance, stern flap, appendage, trailing edge down, computational fluid dynamics

1. Introduction

The International Maritime Organization (IMO) issues a regulation on the Energy Efficiency Design Index (EEDI) to reduce the greenhouse effect caused by emissions from shipping ships. Emissions from ships account for 2.5% of total global emissions and are expected to increase to 5% by 2050 [1]. The efficiency of a ship can be seen from the fuel consumption per unit time. Ship resistance is a factor that determines fuel consumption because the main engine is chosen based on the total drag on the ship.

Ship resistance is a fluid force acting on the ship in such a way that it opposes the ship's movement [2]. If the resistance of the ship can be reduced, the power needed to push the ship to reach the planned speed is also reduced or with the same power the ship sails faster [3].

One way that can be done to overcome these problems is by making modifications to the shape of the ship. In the research that has been carried out, several innovations have been produced such as the bulbous bow, stern wedge, and hull vane which have been proven to



increase the efficiency of the ship. The use of a stern wedge can reduce the total resistance value by 5.47% [4]. Meanwhile, the use of the hull vane on the 750 DWT pioneer vessel can reduce the drag on the ship by 11,839% [5].

Increasing the efficiency of the ship by reducing the value of the resistance can also be done by modifying the addition of a stern flap. The stern flap is an appendage in the form of an additional length at the stern of the ship [6]. The basic advantage of the ship is the change in the flow path after the propeller [7] which results in reduced drag at the stern, reduces energy loss due to wave formation and changes the wave resistance of the ship [8].

The use of stern flaps on KRI Todak proves that the stern flap installed on the full line of the ship is able to reduce total resistance on the ship by 2.24% [9]. In Research [10] it was also explained that a stern flap can increase the maximum speed of the ship by 6.40%. The stern flap changes the pressure distribution at the stern of the ship and results in increased lift. This is very influential on changes in ship trim which can improve the movement of ships experiencing stern trim that is too large so that there is an increase in ship resistance due to the displacement of the LCF (Longitudinal Center of Flotation) point backwards [11].

This research will look at the effect of the length and angle of the stern flap attached to the lower transom on the performance of a 60 m fast boat using the Computational Fluid Dynamic (CFD) method. Computational Fluid Dynamic (CFD) is a tool used to analyze the flow around the hull that is not limited by the size or speed of the ship, and a wider range of applications [12]. The stern flap with geometric variations, namely length and angle, will be analyzed at FN velocity 0.443; FN 0.554 and FN 0.665. This study did not conduct tests on towing tanks.

This study aims to determine the effect of stern flaps on lift, drag and trim that occur on ships. With the aim of this research, it is hoped that this research will be useful for the development of shipping technology, especially in terms of ship powering efficiency and fuel consumption.

2. Methods

2.1. Object of research

The object of this research is a modification of the 60 m fast boat which is given an additional stern flap on the transom (**Figure 1**). Ship dimension is shown in **Table 1**. The method used in this study is the computational fluid dynamic (CFD) method using Tdyn 15.1.0 software.

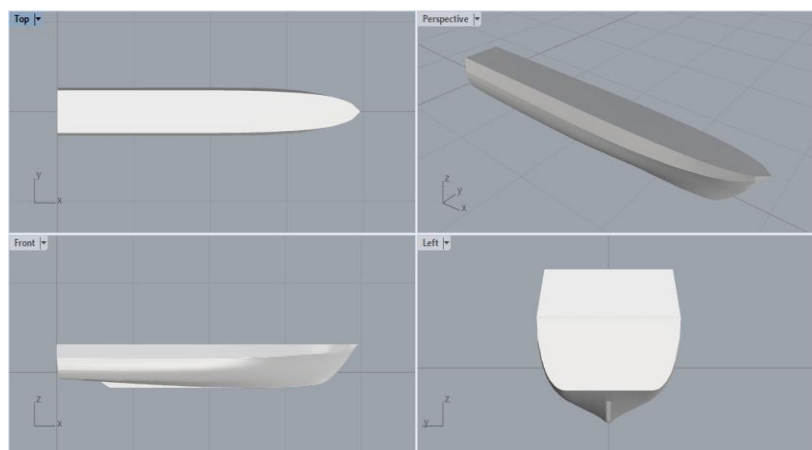

Figure 1. Original ship model

Tabel 1. Principle dimension

No	Principle Dimension Data	
1	Length Over All	59.543 m
2	Length of Waterline	54.850 m
3	Length Between Perpendicular	53.567 m
4	Breadth	8.10 m
5	Height	4.90 m
6	Draft	2.60 m

2.2. Treatment of research objects

This research is focused on the effect of adding a stern flap on a 60 m fast boat on the dynamic performance of the ship. The parameters used are as follows and also in **Table 2**.

- Fixed Parameters :
 1. Hull Dimension :
 - a. Length perpendicular (L_{pp}) (m)
 - b. Breadth (B)(m)
 - c. Draft (T) (m)
 2. Span stern flap
 3. Posisi stern flap
- Variable Parameters :
 1. Length of stern flap
 - a. 1,5 % L_{pp}
 - b. 2 % L_{pp}
 2. Trailing edge down (TED) angle
 - a. 6°
 - b. 9°
 - c. 12°
 3. Ship of Speed in FN 0,445; 0,554; 0,665

Table 2. Stern flap geometry data

No	Model	Chord Length		Span	TED
		(% L_{pp})	(m)		
1	Flap I	1.5 %	0.054 m	0.33 m	6°
2	Flap II	1.5 %	0.054 m	0.33 m	9°
3	Flap III	1.5 %	0.054 m	0.33 m	12°
4	Flap IV	2 %	0.071 m	0.33 m	6°
5	Flap V	2 %	0.071 m	0.33 m	9°
6	Flap VI	2 %	0.071 m	0.33 m	12°

2.3. Trim correction

The trim angle correction equation used on the stern flap follows equation 1 [13] :

$$\Delta\alpha = \frac{My}{\rho g I_y} \quad (1)$$

Where $\Delta\alpha$ trim angle correction, My is Trim Moment, ρ is the density of fluids, g is gravity acceleration dan I_y is Innertia moment y-axis (*pitching*).

2.4. Heaving value correction

The heave value correction equation used on the stern flap follows equation 2.

$$\Delta z = \frac{F_z}{\rho g A_{wp}} \quad (2)$$

where Δz is heaving correction, F_z is Lift force, ρ is density of fluids, g is gravity acceleration and A_{wp} is wetted surface area of hull

2.5. Moment inertia of pitching

The moment of inertia of the pitching on the stern flap is calculated by the following equation 3 [14]

$$I_{yy} = \frac{1}{g} \sum [w_i (x_i^2 + z_i^2)] \quad (3)$$

where g is gravity acceleration, w_i weight each fraction, x_i is distance from CG each fraction to CG of ship and z_i is vertical distance from CG each fraction of ship Center Gravity (CG).

2.6. Force lift

Based on the dimensional analysis of the form of the lift force equation used are as follows [15]:

$$L = \frac{1}{2} \rho V^2 A_p C_L \quad (4)$$

Where L is lift force ρ is the density, C_L is coefficient lift, V is Speed and A_p is plan area.

2.7. Variations of speed

This study will analyze the effect of adding a stern flap at a speed of 20 to 30 knots or the Froude number 0.443 to 0.665.

Table 3. Ship speed variation

Fr	V	
	m s ⁻¹	knot
0.443	2.650	20
0.554	3.317	25
0.665	3.981	30

3. Result and discussion

3.1 Design model of ship hull

The ship model and stern flap variations in this study were designed using 3D software. The results of the ship model were modified by adding a stern flap to the transom of the ship. Original size goes first on a scale of 1: 15.03. The ship model is then exported in the form of an .iges file. Then it will be analyzed using the CFD Tdyn 15.1.0 software.

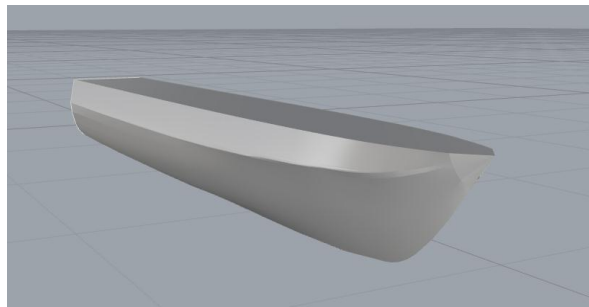

Picture 2. Original ship model

3.2 Modeling of stern flap variation

This research was conducted with a modification in the form of adding a flap with two chord length configurations, namely 1.5% LPP and 2% LPP. The flap model in Figure 2 with a chord length variation of 1.5% LPP or 0.054 m and 2% LPP or 0.071 m will be mounted on the stern of a 60 m fast boat with a predetermined angle variation, namely the trailing edge down (TED) angle or negative angle. 6° , 9° and 12° .

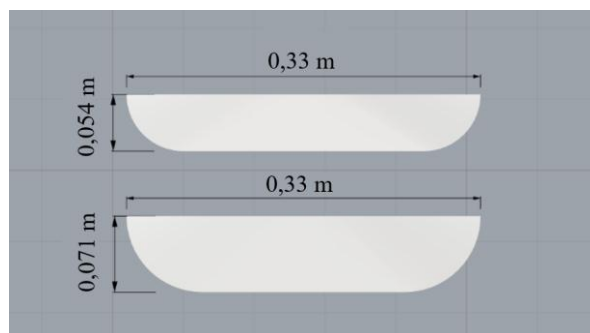

Picture 3. Model flap with variation of chord length

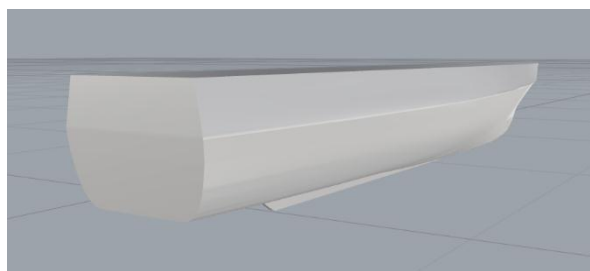

Picture 4. Original ship model

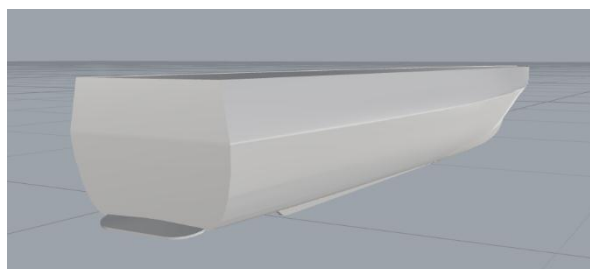

Picture 5. Ship model with the addition of a stern flap

Table 4. The result of changes in volume on the ship after modification.

No	Model	Volume Displacement (m ³)	Difference (%)
1	Original	0.1336	-
2	Flap I	0.1337	0.11%
3	Flap II	0.1337	0.11%
4	Flap III	0.1337	0.11%
5	Flap IV	0.1338	0.15%
6	Flap V	0.1338	0.15%
7	Flap VI	0.1338	0.15%

Table 5. The results of changes in the wet area on the ship after modification.

No	Model	Wetted Surface Area (m ²)	Difference (%)
1	Original	2.010	-
2	Flap I	2.046	1.77%
3	Flap II	2.046	1.77%
4	Flap III	2.046	1.77%
5	Flap IV	2.056	2.28%
6	Flap V	2.056	2.28%
7	Flap VI	2.056	2.28%

3.3 Validation of ship models

The total resistance is the accumulation or sum of the viscosity resistance and the wave resistance. Barriers analysis used a scale of comparison between the model and the prototype, namely 1: 15.03. To validate the obstacles in this study, namely by comparing the results of the obstacles in the CFD software with the previous testing of the results of the towing tanks to ensure that the model created represents the original model. The model is declared valid if the original model validation falls into the validation range, which is $\pm 5\%$. Based on the data in Table 6, the C_T difference between the test results of the towing tank and the CFD test results is less than 5% at each speed. This validation is used to adjust the convergence of the appropriate meshing sizes.

Table 6. Comparison of experimental R_T values and R_T CFD

F_n	V (m/s)	C_T Experiment	C_T CFD	Error (%)
0.665	3.980	112.38	112.63	0.22%

3.4 Ship lifting force and trim moment

Analysis of the performance of the 60 m fast boat with the addition of a stern flap was carried out with two running stages to get the results. The first stage is to find the value of the lift force generated, the trim moment, heave and the trim value of the ship according to the equilibrium when the ship is moving at each speed. The analysis was performed using the computational fluid

dynamic method with Tdyn 15.1.0 software. In the post processor, after the analysis is taken from the results stage.

Table 7. Lift force (N)

No	Model	Froude Number		
		0.443	0.554	0.665
1	Original	1119.50	1166.60	1214.20
2	Flap I	1206.80	1264.20	1293.10
3	Flap II	1219.20	1268.70	1301.10
4	Flap III	1228.30	1277.50	1307.90
5	Flap IV	1239.20	1280.90	1318.90
6	Flap V	1253.80	1285.60	1322.90
7	Flap VI	1250.90	1289.80	1316.90

Based on **Table 7**, the lift value on ships with variations in the addition of stern flaps has increased lift compared to the original model at each speed. The highest lift value was obtained in the Froude number 0.665, namely the V flap variation with a value of 1322.90 N, while the smallest lift value at the same Froude number was found in the flap I variation with a value of 1293.10 N.

Table 8. Moment force (Nm)

No	Model	Froude Number		
		0.443	0.554	0.665
1	Original	2232,72	2259,80	2278,98
2	Flap I	1921,81	1859,18	1835,59
3	Flap II	1889,26	1829,45	1826,04
4	Flap III	1864,18	1823,82	1811,98
5	Flap IV	1789,20	1771,56	1745,98
6	Flap V	1752,34	1726,19	1677,84
7	Flap VI	1757,12	1728,61	1695,47

The lift value data and the trim moment value are processed using equation (1), then the heave and trim values of all models are obtained for each Froude number. The heave value is used to obtain a new laden vessel. The new load is obtained from the reduction of the original vessel load with the heave value.

Table 9. New draft value (m)

No	Model	Froude Number		
		0.443	0.554	0.665
1	Original	0.1464	0.1453	0.1442
2	Flap I	0.1447	0.1434	0.1427
3	Flap II	0.1444	0.1433	0.1425
4	Flap III	0.1442	0.1431	0.1424
5	Flap IV	0.1440	0.1430	0.1422
6	Flap V	0.1436	0.1429	0.1421
7	Flap VI	0.1437	0.1428	0.1422

The new loaded value is inversely proportional to the heave value, because the new loaded value is obtained from subtracting the original loaded value from the heave value, so the larger the heave value the smaller the new loaded value. The new load value is also inversely proportional to the lift value. The higher the lift value, the greater the part of the ship that is lifted and the wet area of the ship is reduced so that the vessel is smaller.

Table 10. Trim angle (deg)

No	Model	Froude Number		
		0.443	0.554	0.665
1	Original	1.107	1.121	1.130
2	Flap I	0.953	0.922	0.910
3	Flap II	0.937	0.907	0.906
4	Flap III	0.924	0.904	0.899
5	Flap IV	0.887	0.879	0.866
6	Flap V	0.869	0.856	0.832
7	Flap VI	0.871	0.857	0.841

Based on **Table 10**, the largest trim angle value occurs in the original model at each speed. There was a decrease in the trim value due to the addition of a stern flap. The largest reduction in trim occurred in the V flap model, namely 0.8320 compared to the original model of 1.1300. This value occurs Froude number 0.665. Equilibrium conditions occur when the ship is freshly loaded and the trim value is applied at the Longitudinal Center of Floatation (LCF). So that the ship is no longer in a straight 180° condition but experiences several degrees of trim according to its value. Modified ships have a different heave or trim angle increase for each Froude number, the increase and trim affect the characteristics of the hull so that changes in displacement and wet area of the ship occur with the following data:

Table 11. New displacement value (ton)

No	Model	Froude Number		
		0.443	0.554	0.665
1	Original	0.101	0.099	0.098
2	Flap I	0.098	0.096	0.095
3	Flap II	0.097	0.096	0.095
4	Flap III	0.097	0.095	0.094
5	Flap IV	0.097	0.095	0.094
6	Flap V	0.096	0.095	0.094
7	Flap VI	0.096	0.095	0.094

Table 12. Wetted surface area (m^2)

No	Model	Froude Number		
		0.443	0.554	0.665
1	Original	1.833	1.823	1.817
2	Flap I	1.790	1.778	1.773
3	Flap II	1.787	1.777	1.771
4	Flap III	1.786	1.776	1.769

5	Flap IV	1.784	1.775	1.768
6	Flap V	1.780	1.774	1.766
7	Flap VI	1.781	1.773	1.768

3.5 Ship viscosity resistance

Viscosity resistance is a resistance that is influenced by the thickness of the fluid rubbing against the submerged body of the ship. The viscosity resistance value decreases as the wet surface area of the vessel decreases. This change is due to the lift force which causes the hull to lift. The following are the results of the viscosity resistance analysis. The analysis results in Table 13 and Figure 5 show that the largest reduction in viscosity resistance is the VI flap model of 4.53%, from 35.769 N to 34.150 N at a froude number of 0.554.

Table 13. Viscosity Resistance (N)

No	Model	Froude Number		
		0,443	0,554	0,665
1	Original	23,231	35,769	43,942
2	Flap I	22,963	35,413	43,703
3	Flap II	22,682	35,356	43,674
4	Flap III	22,611	35,104	43,354
5	Flap IV	22,501	34,698	43,249
6	Flap V	22,269	34,680	42,911
7	Flap VI	22,337	34,650	42,948

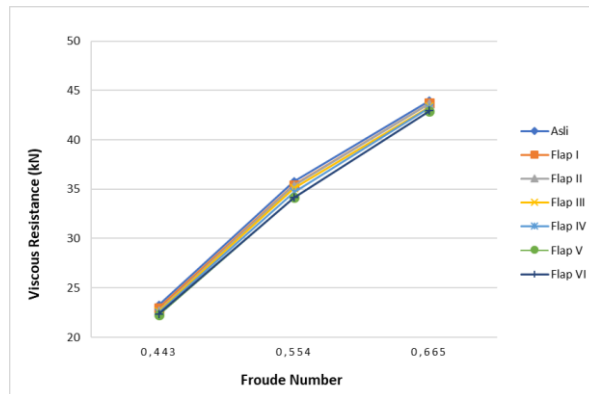

Picture 6. Chart of viscosity resistance

3.6 Wave Resistance of Ship

Wave resistance is an resistance that is formed due to movement of the water by the hull, causing waves either when the water is calm or in a bumpy state. Following are the results of the analysis of wave resistance.

Table 14. Wave resistance (N)

No	Model	Froude Number		
		0,443	0,554	0,665
1	Original	36,503	55,591	68,688

2	Flap I	35,274	54,907	67,239
3	Flap II	34,638	54,800	67,180
4	Flap III	34,675	53,093	67,100
5	Flap IV	34,523	53,475	66,973
6	Flap V	34,164	53,001	66,599
7	Flap VI	34,196	52,774	66,974

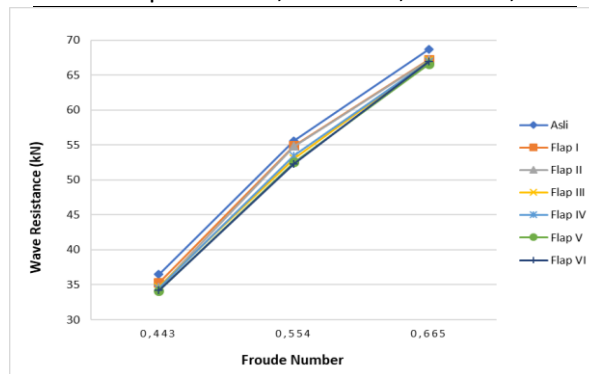

Picture 7. Chart of Wave Resistance

The results of the analysis in Table 14 and Figure 6 show that the largest reduction in wave resistance is in the flap model V froude number 0.443 with a decrease of 6.41%, from 36.50 N to 34.20 N.

3.7 Total of ship resistance

The total ship resistance is obtained from the sum of the viscosity resistance and also the wave resistance. To see the numerical results of total resistance on Tdyn 15.1.0 software using the pre-determined meshing data, it can be seen after running the data in the "force on boundaries" menu. Following are the simulation results of total resistance analysis.

Table 15. Total of Ship Resistance (N)

No	Model	Froude Number		
		0,443	0,554	0,665
1	Original	59,734	91,360	112,630
2	Flap I	58,237	90,320	110,942
3	Flap II	57,320	90,156	110,854
4	Flap III	57,286	88,197	110,454
5	Flap IV	57,024	88,173	110,222
6	Flap V	56,433	86,681	109,510
7	Flap VI	56,533	86,424	109,922

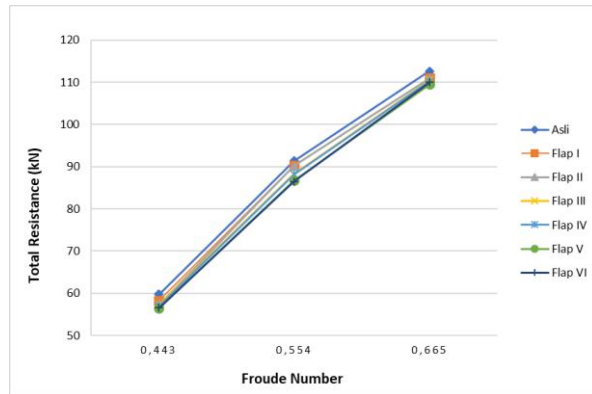

Picture 8. Chart of the total of resistance

Based on table 15 and Figure 7, it can be seen that the total resistance due to the addition of a stern flap has decreased in each of its variations. The analysis results show that the V flap model reduces the resistance better at each speed. In the froude number 0.443 there was a decrease of 5.53%, the froude number was 0.554 by 4.80% and the froude number was 0.665 by 2.77% compared to the original model.

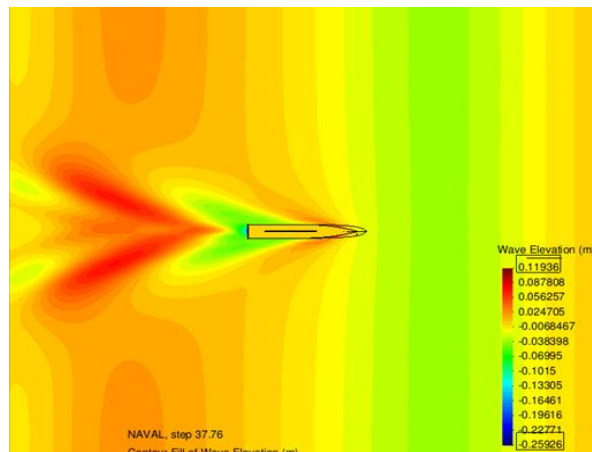

Picture 9. Contour fill wave elevation original model in froude number 0,664

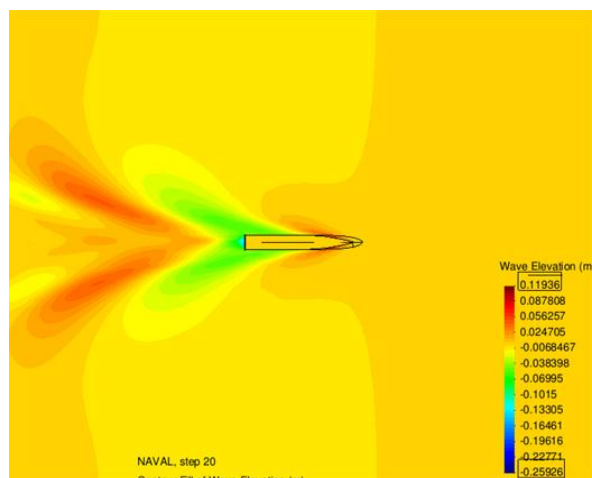

Picture 10. Contour fill wave elevation model flap V in froude number 0,664.

Ships with a stern without flaps produce eddy around the stern where these eddies absorb the energy of the ship for the formation of waves in the stern area. This reduction in eddy vortex formation can be done by adding a flap to the stern. The flap will optimize the energy wasted due to wave formation, so that the resulting wave height will also be reduced.

The analysis results in Figure 8 and Figure 9 show that the original model wave pattern has a sharper color than the flap V model at a froude number of 0.665. This is in accordance with the theory regarding the ability of stern flaps to reduce energy wasted due to wave formation [16].

4. Conclusion

From the six variations of the analyzed model, it is found that the largest lift value is generated by the V flap model with a difference in the froude number of 0.665, namely from 1322.90 N. Meanwhile, the lowest lift value is generated by the flap I model which is 1293.10 N at the same froude number.

The result of the analysis of total resistance that has the best reduction in resistance is the V flap model with a flap length of 2% LPP and a trailing edge down (TED) angle of 9° . The greatest reduction of resistance occurred in the V flap model with a total resistance of 56.433 N or a difference of 5.53% of the total resistance of the original or unmodified ship at the same speed, namely the froude number 0.443. Ships with modifications to the addition of a stern flap at the stern are proven to be able to reduce the trim angle that occurs on the ship. In the Froude number 0.665 the original ship trim value is 1.1300, while in the V flap model the trim value that occurs is 0.832° . Difference 26.38% between the original model and the modified model of adding flaps.

The efficiency of using the flap depends on the configuration of the chord length and trailing edge down (TED) angle used. Different configurations can produce almost the same efficiency.

5. References

- [1] International Maritime Organization. Third IMO greenhouse gas study 2014 executive summary. London UK:International Maritime Organization; 2015
- [2] R F. A. Molland, R. S. Turnock and A. D. Hudson, *Ship Resistance and Propulsion: Practical estimation of ship propulsive power*, 2011
- [3] Y. H. Ozdemir, A. Dogrul, and B. Barlas, "A Numerical Application To Predict The Resistance And Wave Pattern Of Kriso Container Ship," no. June, 2016.
- [4] A. D. Alfian, D. Chrismianto, and E. S. Hadi, "ANALISA HAMBATAN AKIBAT PENAMBAHAN STERN WEDGE PADA KRI TODAK MENGGUNAKAN METODE CFD (COMPUTATIONAL FLUID DYNAMIC)," Univ. Diponegoro, vol. 4, no. 4, pp. 779–786, 2016
- [5] Sihombing D. M., Amiruddin W., Iqbal M. 2019. "Analisa Performa Hull Vane Terhadap Hambatan dan *Seakeeping* Kapal Perintis 750 DWT dengan Variasi Foil Menggunakan Metode CFD"
- [6] O. Yaakob, S. Shamsuddin, and K. Kho King, "Stern Flap For Resistance Reduction Of Planing Hull Craft: A Case Study With A Fast Crew Boat Model," *Univ. Teknol. Malaysia*, vol. Stern Flap, pp. 43–52, 2004.
- [7] M. Salas, J. Rosas, and R. Luco, "Hydrodynamic analysis of the performance of stern flaps in a semi-displacement hull," *Lat. Am. Appl. Res.*, vol. 34, no. 4, pp. 275–284, 2004.
- [8] E. Jadmiko, I. S. Arief, and L. Arif, "Comparison of Stern Wedge and Stern Flap on Fast Monohull Vessel Resistance," *Int. J. Mar. Eng. Innov. Res.*, vol. 3, no. 2, pp. 41–49, 2018.
- [9] J. Harumbing, D. Chrismianto, and E. S. Hadi, "ANALISA HAMBATAN AKIBAT PENAMBAHAN

- STERN FLAP PADA KAPAL KRI TODAK MENGGUNAKAN METODE COMPUTATIONAL FLUID DYNAMIC (CFD),* *Univ. Diponegoro*, vol. 4, no. 4, pp. 758–767, 2016.
- [10] D. S. Cusanelli, “Scaling Effects on Stern Flap Performance Progress Report,” *West Bethesda*, 2009.
- [11] M. M. Z. B, P. H. Rukmono, and M. Basuki, “Pengaruh Variasi Sudut Masuk Trim Tab Pada Fast Patrol Boat 60 Meter Menggunakan Pendekatan CFD,” pp. 181–194, 2016.
- [12] L. Xu, D. He, and D. Wan, “Research Status and Analysis of the Ship Hydrodynamic Energy-saving Devices.”
- [13] W. B. P. Daniel Savitsky, “Procedures for Hydrodynamic Evaluation of Planing Hulls in Smooth and Rough Water.” 1976.
- [14] G. D. Villa, “a Systematic Cfd Analysis of Flaps / Interceptors,” 10th Int. Conf. Fast Sea Transp., no. October, pp. 1023–1038, 2009.
- [15] R. Bhattacharyya, *Dynamics of Marine Vehicles*, 1st ed. New York: A Wiley Interscience Publication, 1978.
- [16] G. Karafiath, D. S. Cusanelli, and C. W. Lin, “Stern wedges and stern flaps for improved powering—US Navy experience,” *Trans. - Soc. Nav. Archit. Mar. Eng.*, vol. 107, pp. 67–99, 1999.