

Power Consumption Analysis in Resonant Converter

Mochammad Facta*
Electrical Department
Universitas Diponegoro
Kampus Undip Tembalang, Semarang
mochfacta@gmail.com;
facta@elektro.undip.ac.id

Hermawan
Electrical Department
Engineering Faculty
Universitas Diponegoro
Semarang, Indonesia
hermawan.60@gmail.com

Muhammad Amjad
Department of Electronic Engineering
The Islamia University of Bahawalpur
Bahawalpur, Pakistan
muhammad.amjad@iub.edu.pk

Abstract— Resonant converter equipped with single switch and resonant bank is the simplest converter to generate alternating higher voltage at high frequency. This topology is suitable to convert a considerable lower voltage such as battery or photovoltaic to higher voltage in order of kilo Volt, so that it crucial to estimate the power consumption inside the resonant converter. Most of previous records revealed only the work mechanism of the resonant converter, but explicit records present their power consumption. This paper describes the power consumption for single switch resonant converters as direct to alternating current converter. The converter is combined with parallel bank converter, piezoelectric transformer and ferrite transformer. As the results of formulation the power consumption of resonant converters with three variation of bank, the efficiency of three kind of converter is obtained.

Keywords—resonant converter, dc to ac converter, piezoelectric transformer, ferrite transformer.

I. INTRODUCTION

Among several topologies in power electronics dedicated to generate higher voltage than its input, the resonance converter power supply is the most interesting to investigate. Previous resonance topologies used more than one switch to generate the desired output, such as half bridge and full bridge topology [1, 2]. Resonant converter equipped with only one switch is more interesting to study because of its simplicity and low part count [3, 4]. It also has a small footprint, and consumes very low power, which is suitable to convert portable power supply in which the main source is battery or photovoltaic [5, 6]. In previous records [3, 7-9] the work mechanism of the resonant converter become the main focus of work, but explicit records present the power consumption is few. As the topology of converter using only one switch, it crucial to estimate the power consumption inside resonant converter. In this paper, power consumption of a resonant converter using one switch as direct to alternating current converter is studied. The converter is investigated by combine the circuit with parallel bank converter, piezoelectric transformer and ferrite. Three circuits are studied in detail calculation and implemented using hardware to verify the power formulation.

II. POWER COMPUTATION FOR RESONANT CONVERTER WITH PARALLEL BANK

Resonant converter with parallel bank consists of direct current side (dc side) and alternating current side (ac side) as it is described in Fig. 1 and this topology is called circuit-1.

The single switch M_1 plays the main role to convert dc voltage to pulse voltage. The inductor L_f as a choke provides electrical energy as it is charged during switch M_1 is off. The internal resistance of L_f is named as r_{L_f} . The ac side consist of several passive i.e. inductor, capacitor and resistor as a load. The passive element acts as parallel bank to create alternating current during resonant mode.

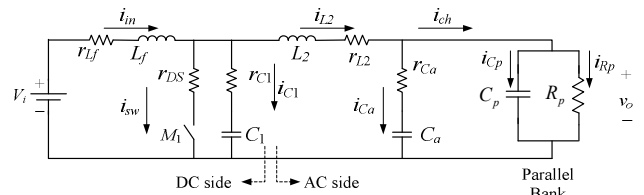

Fig. 1. Schematic circuit for resonant converter with parallel bank.

The total active power (P_{tot}) consumed by the SSRC with PLR circuit (based on Figure 5.1) can be estimated using the following expression:

$$P_{tot} = P_{out} + P_{r_{L_f}} + P_{r_{DS}} + P_{r_{C_1}} + P_{r_{L_2}} + P_{r_{C_a}} \quad (1)$$

where

$P_{r_{L_f}}$ is power losses at inductor L_f ,

$P_{r_{DS}}$ is power losses at switching device,

$P_{r_{C_1}}$ is power losses at shunt capacitor C_1 ,

$P_{r_{L_2}}$ is power losses at inductor L_2 , and

$P_{r_{C_a}}$ is power losses at C_a .

Its efficiency is given by

$$\eta = \frac{P_{out}}{P_{tot}} = \frac{P_{out}}{P_{out} + (P_{r_{L_f}} + P_{r_{DS}} + P_{r_{C_1}} + P_{r_{L_2}} + P_{r_{C_a}})} \quad (2)$$

where P_{out} is the ac power measured at the input of the load. At the ac side during resonant mode, the sinusoidal voltage (v_o) appears across C_p at the parallel bank and C_a . Consequently, the sinusoidal resonant current flows through the parallel bank can be written in phasor form as

$$i_{ch} = \frac{I_{chm}}{\sqrt{2}} \sin(\omega t + \theta_{ch}) = \frac{I_{chm}}{\sqrt{2}} \angle \theta_{ch} \quad (3)$$

If I_{Cam} is the maximum current flowing through C_a , the power dissipated by the internal at resistance of C_a can be formulated as:

$$P_{r_{C_a}} = r_{C_a} \frac{I_{Cam}^2}{2} \quad (4)$$

As I_{L2m} is the maximum current flowing through L_2 , the dissipated power at internal resistance of the resonant inductor (r_{L_2}) can be expressed as:

$$P_{r_{L_2}} = r_{L_2} \frac{I_{L2m}^2}{2} \quad (5)$$

At the dc side, the effective current flowing through the switch is defined as [8, 10]:

$$i_{sw_{rms}} = i_{in} \sqrt{2-D + \frac{2\pi(1-D)^2(\pi D + \frac{1}{4}[\sin(2\phi) - \sin(4\pi D + 2\phi)])}{(\cos(2\pi D + \phi) - \cos(\phi))^2}} \quad (6)$$

then, the dissipated power at the switching device due to the presence of r_{DS} is written as :

$$P_{r_{DS}} = r_{DS} i_{sw_{rms}}^2 \quad (7)$$

If the effective current flowing through C_1 is [8] :

$$i_{c1_{rms}} = i_{in} \sqrt{D-1 + \frac{2\pi(1-D)^2(\pi(1-D) + \frac{1}{4}[\sin(4\pi D + 2\phi) - \sin(2\phi)])}{(\cos(2\pi D + \phi) - \cos(\phi))^2}} \quad (8)$$

the dissipated power at r_{C1} can be computed as

$$P_{r_{C1}} = r_{C1} i_{c1_{rms}}^2 \quad (9)$$

When i_{in} flows through L_f ; consequently, the dissipated power r_{L_f} is

$$P_{r_{L_f}} = r_{L_f} i_{in}^2 \quad (10)$$

Later, the equivalent series resistance values of r_{L_f} , r_{C1} , r_{L_2} , and r_{C_a} are determined by LCR meter, while r_{DS} is found in manufacturer's data sheet.

III. POWER COMPUTATION FOR RESONANT CONVERTER WITH PIEZOELECTRIC TRANSFORMER

Resonant converter with piezoelectric transformer also consists of direct current side (dc side) and alternating current side (ac side) as it is described in Fig. 2 and this topology is called circuit-2. The dc side circuit is similar with topology at Fig. 1. The ac side consist of several parasitic passive element model namely inductor, coupling inductor as model of step up voltage, capacitor and resistor as a load. Overall the model of piezoelectric transformer acts as as parallel bank to create alternating current at resonant operation.

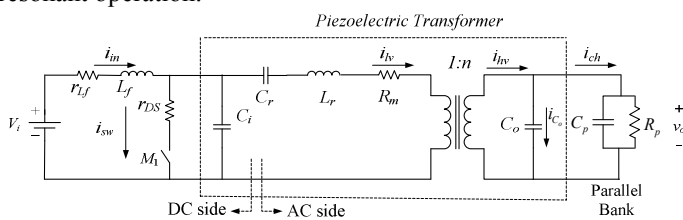

Fig. 2. Model circuit for resonant converter with piezoelectric transformer.

The total power loss is the sum of the inductor loss ($P_{r_{L_f}}$), switching device loss ($P_{r_{DS}}$) and the mechanical resistance of the PT loss (P_{R_m}). Considering these factors, the efficiency can be written as:

$$\eta = \frac{P_{out}}{P_{out} + (P_{r_{L_f}} + P_{r_{DS}} + P_{R_m})} \quad (11)$$

where P_{out} is power consumed at resistive load R_p

At dc side, the formulation for of the inductor loss ($P_{r_{L_f}}$), switching device loss ($P_{r_{DS}}$) are similar with Eq. (7) and (10). At the ac side, the resonant current flowing through the chamber, i_{hv} , then if i_{hv} is transformed to current at the primary side i_{lv} through the turn ratio of the PT (a) as follows:

$$i_{lv_m} = a \times i_{hv_m} \quad (12)$$

where i_{hv_m} is maximum current of i_{lv} . It is noted that i_{lv} becomes a total current flowing to the ac side and flows through R_m . The losses at mechanical branch resistance can be written as:

$$P_{r_m} = R_m \frac{i_{lv_m}^2}{2} \quad (13)$$

The relation between i_{lv_m} , i_{in} and the duty cycle (D) can be formulated as:

$$i_{in} = i_{lv_m} \left[\frac{\cos(2\pi D + \phi) - \cos(\phi)}{2\pi(1-D)} \right] \quad (14)$$

The resistance of r_{L_f} is measured directly by LCR meter.

The values of r_{DS} and R_m are obtained from the manufacturer's data sheet of piezoelectric.

IV. POWER COMPUTATION FOR RESONANT CONVERTER WITH FERRITE TRANSFORMER

Resonant converter with ferrite transformer is set up by direct current side (dc side) and alternating current side (AC side) as it is described in Fig. 3 and this topology is called circuit-3. The dc side circuit is similar with topology at Fig. 1. The ac side has several passive element such as coupling inductor as model of step up ferrite transformer, capacitor and resistor as a load. Combination model ferrite transformer, capacitor and resistive behave as a bank to create sinusoidal output voltage at resonant frequency.

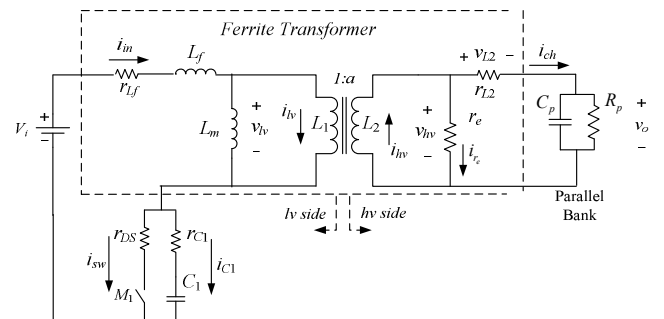

Fig. 2. Schematic circuit for resonant converter with ferrite transformer.

Based on these loss components, the efficiency can be calculated as:

$$\eta = \frac{P_{out}}{P_{out} + (P_{r_{L1}} + P_{r_e} + P_{r_{DS}} + P_{r_{C1}} + P_{r_{L2}})} \quad (15)$$

At dc side Eq. 6 and 8 are used to calculate current at switch M_1 and parallel capacitor C_1 . Furthermore, the formulation for of switching device loss ($P_{r_{DS}}$), dissipated power at r_{C1} ($P_{r_{C1}}$) and a choke loss ($P_{r_{L_f}}$) can be computed by using Eq. (7), (9) and (10).

At the high voltage side, the resonant current flowing through the output at load side (i_{ch}) is sinusoidal. If i_{ch} is the total current flowing in the secondary side, the loss at the secondary winding of the transformer is written as:

$$P_{r_{L2}} = r_{L2} \frac{I_{chm}^2}{2} \quad (16)$$

where I_{chm} is maximum current of i_{ch} . The voltage at the high voltage side (v_{hv}) can be found as the summation of output voltage (v_o) and voltage drop in secondary winding (v_{L2}) and it follows:

$$v_{hv} = v_{L2} + v_o \quad (17)$$

$$v_{hv} = i_{ch} r_{L2} + v_o \quad (18)$$

The total current at the high voltage side is

$$i_{hv} = i_{ch} + i_{r_e}$$

The current flowing through r_e is obtained from

$$i_{r_e} = \frac{v_{hv}}{r_e} \quad (19)$$

By knowing the value of r_e from ferrite's data sheet, then

$$P_{r_e} = r_e \frac{i_{rem}^2}{2} \quad (20)$$

where I_{rem} is maximum current of i_{re} .

V. EXPERIMENTAL RESULTS AND DISCUSSION

Table 1 until 3 show the values of internal resistance for each topology.

TABLE I. THE VALUES OF INTERNAL RESISTANCE IN CIRCUIT-1

Component	Value
r_{L_f}	168.00 mΩ
r_{DS}	180.00 mΩ
r_{C1}	75.30 mΩ
r_{L2}	4.55 Ω
r_{C_a}	1.32 Ω

TABLE II. THE VALUES OF INTERNAL RESISTANCE IN CIRCUIT-2

Component	Value
r_{L_f}	10.0 mΩ
r_{DS}	180.0 mΩ
R_m	83.0 mΩ

TABLE III. THE VALUES OF INTERNAL RESISTANCE IN CIRCUIT-3

Component	Value
r_{L2}	244.00 Ω
r_e	5.40 MΩ
r_{L_f}	10.00 mΩ
r_{DS}	180.00 mΩ
r_{C1}	89.40 mΩ

Figure 4 shows the calculated and measured total output power of circuit-1. As can be seen, the calculated power is in very close agreement with the measurement. At high frequency, the r_{L2} contribution to losses is very significant due to the fact that the ac resistance value of inductor (R_{AC}) is much greater than dc resistance value (R_{DC}). This is due to the skin depth and proximity effect at high frequency operation.

Figure 6 shows the calculated and measured total output power of circuit-1. As can be seen, the calculated power is in very close with the measurement. The similar agreement between measurement and calculation is also shown in Fig. 7 for efficiency for circuit-2. The efficiency of circuit-2 is high due the absence of windings. The absence of internal resistance R_m in the piezoelectric transformer minimize the power losses.

Figure 8 depicts the calculated and measured input versus output power for circuit-3. As can be seen, they are in very close agreement. Figure 9 shows the efficiency of for circuit-3. Since the measured values are close to the theoretical values, it can be resumed that the efficiency analysis carried out is justified.

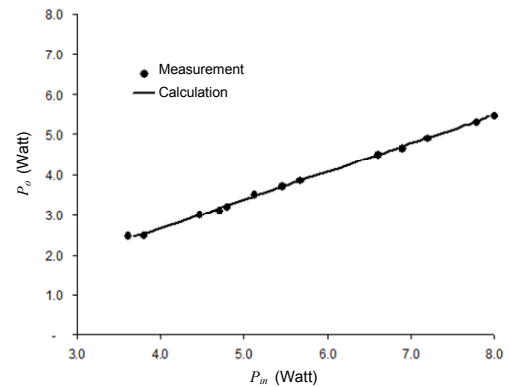

Fig.4. Input and output power of Circuit-1

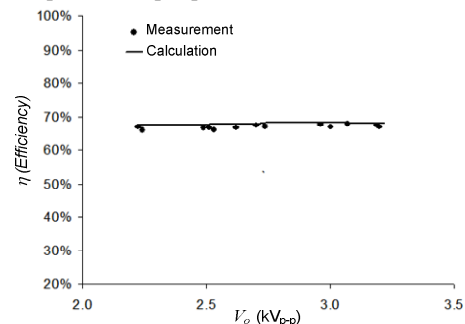

Fig.5. Efficiency of Circuit-1

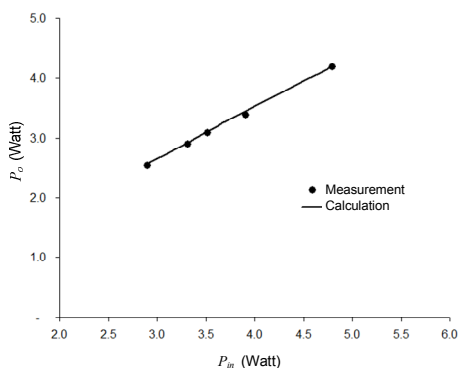

Fig. 6. Input and output power of Circuit-2

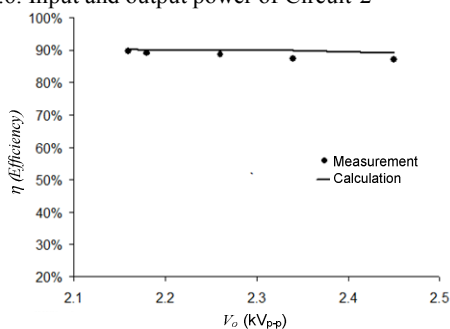

Fig. 7. Efficiency of Circuit-2

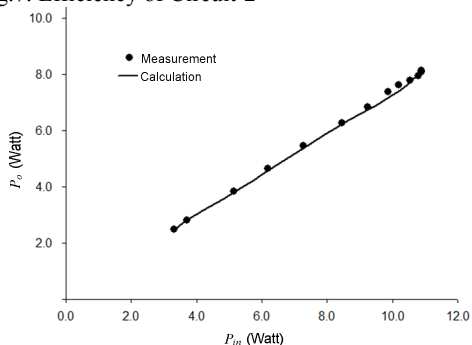

Fig. 8. Input and output power of Circuit-3

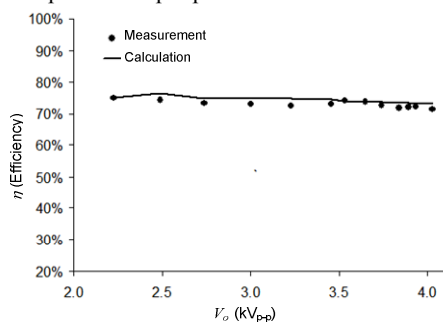

Fig. 9. Efficiency of Circuit-3

VI. CONCLUSION

The work to investigate the power consumption of resonant converter with one switch has been carried out for three variations of circuit i.e. parallel bank, piezoelectric transformer and ferrite transformer. The formulation for power consumption inside the converter also leads to the determination of efficiency for each resonant circuit. Circuit-2 containing piezoelectric transformer has the most efficient power consumption due to the absence of winding inside the piezoelectric transformer. Based on the experimental results, it is shown that the measured values are close to the

theoretical values, it can be resumed that the efficiency analysis carried out is justified.

ACKNOWLEDGMENT

This research is supported by strategic grant research Faculty Engineering, Universitas Diponegoro for grant scheme No. 167/UN.7.5.3/HK/2019, April 22nd, 2019.

REFERENCES

- [1] L. Albertoni, F. Grasso, J. Matteucci, M. C. Piccirilli, A. Reatti, A. Ayachit, M.K. Kazimierczuk, "Analysis and design of full-bridge Class-DE inverter at fixed duty cycle," *IECON 2016 - 42nd Annual Conference of the IEEE Industrial Electronics Society*, 2016, pp. 5609-5614.
- [2] Y. Yang, F. E. Bisogno, A. Schittler, S. Nittayarumphong, M. Radecker, W.J. Fischer, M. Fahlenkamp, "Comparison of Inductor-Half-Bridge and Class-E resonant topologies for piezoelectric transformer applications," *Energy Conversion Congress and Exposition, ECCE 2009*. 2009, pp. 776-782.
- [3] M. Catelani, L. Ciani, A. Reatti, F. Corti, V. Sorrentino, A. Ayachit, M. K. Kazimierczuk, "Reliability analysis and electrical characterization of a Class-E resonant inverter," *2018 IEEE International Instrumentation and Measurement Technology Conference (I2MTC)*, 2018, pp. 1-6.
- [4] H. Jedi, A. Ayachit, M. K. Kazimierczuk, "Resonant gate-drive circuit with reduced switching loss," in *2018 IEEE Texas Power and Energy Conference (TPEC)*, 2018, pp. 1-6.
- [5] M. Facta, Hermawan, N. Ayu K. Umiati, Z. Salam, Z. Buntat, "Implementation of photovoltaic and simple resonant power converter for high frequency discharge application," *2nd International Conference on Information Technology, Computer, and Electrical Engineering (ICITACEE)*, 2015.
- [6] M. Facta, Hermawan, Z. Salam, "Simple resonant power converter supplied by photovoltaic for ozonizer," *Proceeding of the Electrical Engineering Computer Science and Informatics*, 2014.
- [7] M. Hayati, S. Roshani, S. Roshani, M. K. Kazimierczuk, H. Sekiya, "Design of Class E Power Amplifier with New Structure and Flat Top Switch Voltage Waveform," *IEEE Transactions on Power Electronics*, 2018, vol. 33, pp. 2571-2579.
- [8] M. K. Kazimierczuk and D. Czarkowski, *Resonant Power Converter*: John Wiley and Sons, 1995.
- [9] M. Amjad, Z. Salam, M. Facta, K. Ishaque, "Design and Development of High-Voltage Transformer-less Power Supply for Ozone Generation Based on Voltage-fed Full Bridge Resonant Inverter" *Journal of Power Electronics*, 2013, vol. 12, pp. 387-398
- [10] M. K. Kazimierczuk, "Class D voltage-switching MOSFET power amplifier," *Electric Power Applications, IEE Proceedings B*, 1991, vol. 138, pp. 285-296.