

INTERPLAY OF INTERGENERATIONAL RELATIONSHIP QUALITY, ENTREPRENEURIAL KNOWLEDGE SHARING, AND BUSINESS PERFORMANCE IN FAMILY FIRMS: A PATH TO FIRM-FAMILY SUSTAINABILITY

IDRIS IDRIS ¹, MUHAMMAD NASIR ², HERSUGONDO HERSOGONDO ^{3*},
TUMPAL SITUMORANG ⁴ and SUGENG WAHYUDI ⁵

^{1, 2, 3, 4, 5} Faculty of Economics and Business - Diponegoro University, Semarang, Indonesia.

*Corresponding Author Email: hersugondo@lecturer.undip.ac.id

Abstract

At present, the focus of family businesses on long-term sustainability is rooted in the achievements of preceding generations. This success reflects the family's control over and inheritance of both wealth and social accomplishments. However, family businesses face challenges such as potential conflicts, emotional disruptions, differences in beliefs, and individual egos, all of which can significantly impact business continuity. Entrepreneurial knowledge sharing represents the interaction and communication between individuals and business units, contributing to a company's strategic development. This culture of knowledge sharing carries implications for enhancing relationships with company resources and serves as a means of preserving values and traditions within a family business. The aim of this research is to examine the Intergeneration Relationship Quality variable as a mediator in addressing the gap in entrepreneurial knowledge-sharing research concerning the sustainability of family businesses. The research sample comprises family business owners in the Central Java region, selected using purposive sampling techniques. The research findings indicate a positive influence on all four hypotheses.

Keywords: Family Company Orientation, Long-Term Sustainability, Entrepreneurial Knowledge Sharing, Relationship Quality, Family Business Constraints.

INTRODUCTION

Family businesses play a significant role in a nation's economic landscape and growth (Memili et al., 2015; Miroshnychenko et al., 2021). Studies indicate that family ownership prevails in family companies not only on a global scale but also in Asia (Anderson et al., 2003; Bennedsen et al., 2010). This is particularly true in Indonesia, where the majority of companies are family-owned (Claessens et al., 2000; Rustam et al., 2021). Consequently, the government is keen on ensuring the continuity of family businesses (Gomez-Mejia et al., 2014).

A family business typically involves two or more family members overseeing its financial aspects (Aronoff et al., 1995; Kayser et al., 2002). Furthermore, research by Anderson et al. (2003) and Tonggano et al. (2017) highlights that families manage and control these businesses. The emotional bonds among family members are a hallmark of family enterprises, contributing significantly to their success and sustainability (Cabrera-Suárez et al., 2001). Various studies (Barroso Martínez et al., 2013; Boyd et al., 2015; Martínez et al., 2016) underscore the distinctions between family and non-family businesses, with the key difference being the

values-based foundation of family companies, wherein the success of the business is a collective contribution of family members.

Within the realm of family businesses, intergenerational tensions, conflicts of interest among family members, resistance to adaptation, and decision-making challenges persist. Several studies suggest that such conflicts can make family businesses vulnerable and ultimately jeopardize their sustainability (Fahed-Sreih, 2018; Pieper et al., 2013). The importance of sustaining family businesses is evident in the literature (Aidford et al., 2014; Botero et al., 2021; Klenke, 2018). To ensure business continuity, it is necessary to develop resources that maintain performance (Koentjoro et al., 2020). This extends to empowering family members from a young age within the family business context (Murphy et al., 2015). The success of family businesses is influenced by factors such as providing opportunities and assistance to family members, reflecting the business's previous generational achievements, and preserving wealth and social recognition (Kellermanns et al., 2008; Berrone et al., 2012; Gómez-Mejía et al., 2007).

The orientation of family businesses is inherently long-term (Y. Wang et al., 2004), and succession to the next generation is a crucial option for ensuring business continuity (Kiwia et al., 2019; Matias & Franco, 2020). This sustainability hinges on the ability of business stakeholders to share experiences and build relationships with the succeeding generation (Mokhber et al., 2017). Family businesses without succession planning are bound to affect family members and business partners (Carlock, 2010; Nordqvist et al., 2010; Songini et al., 2013). Effective succession relies on consistent knowledge sharing and interaction among family members (Suppiah et al., 2011).

Knowledge sharing is imperative for resource development, and numerous studies have explored its impact on business performance (Geiger et al., 2012; Huang et al., 2013). However, knowledge sharing tends to be more prevalent in larger family businesses compared to smaller ones (Chenet et al., 2010; Wong et al., 2004). Its effectiveness is contingent on management's ability to foster a culture of knowledge sharing among company resources, ultimately improving the quality of relationships within the organization (Wening et al., 2016). Knowledge sharing also plays a pivotal role in maximizing resources and enhancing corporate value (Foss et al., 2010).

This research addresses a significant gap in the literature concerning family business sustainability and succession. It adopts a Resource Based View (RBV) theoretical framework (Barney, 2001), which focuses on optimizing and maintaining unique resources and capabilities for long-term competitive advantage. RBV has found extensive application in family business research due to the distinctive advantages offered by resources such as family and cultural ties and decision-making grounded in family values (Neubaum & Micelotta, 2021). The study's central question pertains to the sustainability of family businesses into the next generation, with a specific focus on examining the mediating role of intergenerational relationship quality in the context of entrepreneurial knowledge sharing on family firm sustainability.

LITERATURE REVIEWS

Entrepreneurial Knowledge Sharing and Intergenerational Relationship Quality

The act of sharing knowledge plays a pivotal role in informed decision-making and enhances a company's ability to plan effectively (Hanifah et al., 2021; Oliveira et al., 2020). Resource capabilities, encompassing skills, knowledge, and experience, significantly contribute to the performance of other resources when there is a conducive environment for the exchange of shared knowledge (Buenechea-Elberdin et al., 2018; Oliveira et al., 2020). Business stakeholders who foster a culture of knowledge sharing tend to stimulate the generation of creative ideas (Murray & Palladino, 2020; Unger et al., 2011).

Research (Huggins et al., 2012) underscores that knowledge constitutes the primary asset for small businesses. Small businesses under the governance of family firms actively engage in knowledge sharing to gain a competitive edge for future generations (Daspit et al., 2017; Howorth et al., 2010). Knowledge sharing is regarded as the cornerstone for business development (Zheng et al., 2020). Within family enterprises, the practice of knowledge sharing is facilitated through interactions among family members (Cabrera-Suárez et al., 2001; Scuotto et al., 2017). Several studies affirm that the decision to share entrepreneurial knowledge has a direct impact on enhancing intergenerational relationship quality. This, in turn, streamlines decision-making processes within the company and contributes to the sustainability of family businesses (Barros-Contreras et al., 2020; Chrisman et al., 2005; Lumpkin et al., 2010). Consequently, we present our initial hypothesis:

Hypothesis 1: Entrepreneurial Knowledge Sharing has a positive influence on Intergenerational Relationship Quality.

Intergenerational Relationship Quality and Firm-Family Sustainability

Previous research on the quality of intergenerational relationships has typically focused on examining one or two generations and has not delved into the dynamics of three generations of family members (Fingerman et al., 2008; Fingerman et al., 2011; Pillemer et al., 2002). It is evident that the capacity of business owners to nurture relationships significantly contributes to the sustainability of family businesses (Olson et al., 2003). The continued success and functionality of family businesses are intrinsically tied to the quality of relationships among family members (Allouche et al., 2008; Danes et al., 2009). Nevertheless, it should be noted that there remain discrepancies in research findings when it comes to the dynamics of intergenerational relationships within family businesses (Bengtson et al., 2002).

The sustainability of family businesses hinges on their ability to ensure continuity, which, in turn, is paramount to their continued success and functionality (Allouche et al., 2008; Danes et al., 2009). Families play a substantial role in shaping the trajectory of family businesses (Olson et al., 2003). However, it is essential to acknowledge that there are variations in research outcomes regarding intergenerational relationships within family firms (Bengtson et al., 2002). Several studies suggest that there is a tendency for entrepreneurial behaviors to be passed on to the succeeding generation (Casillas et al., 2010; Mullens, 2018). The process of family

business succession underscores the importance of expanding family businesses, emphasizing job creation, and augmenting the wealth of family members (Martínez et al., 2013).

It is noteworthy that research on intergenerational relationship quality has often concentrated on the examination of one or two generations, neglecting the complex interactions involving three generations of family members (Birditt et al., 2012; Fingerman et al., 2008; Pillemer et al., 2002). As a result, we put forward the following hypothesis:

Hypothesis 2: Intergenerational Relationship Quality has a positive impact on Firm-Family Sustainability.

Intergenerational Relationship Quality and Business Performance

The quality of intergenerational relationships holds significant importance as it serves as a determining factor for the sustainability of family businesses, emphasizing the shared values that underpin these relationships (Bai, 2018; Liu et al., 2021). In family-managed businesses, the family takes on a pivotal role in overseeing the company's operations and assumes the responsibilities of a board member, with a primary focus on ensuring the company's sustainability for future generations (Alderson, 2018). Business stakeholders consistently strive to maintain business continuity by offering guidance and sharing knowledge and experience with the succeeding generation (Alderson, 2018).

A business is classified as a family company when decision-making authority is directly or indirectly held by family members, and the management is entrusted to a family member considered trustworthy (Family Firm Institute, 2013). The quality of relationships meticulously maintained among family members significantly influences the stability of the business (Zachary, 2011). The practice of knowledge-sharing has played a pivotal role in shaping the behavior of corporate resources (S. Wang et al., 2010). Research conducted by Liao et al. (2010) asserts that the quality of relationships established within company activities intensifies the willingness of resources to share knowledge, ultimately contributing to the enhancement of resource and company performance. Activities fostering quality relationships have the capacity to instill trust among family members (Kandade et al., 2021).

The quality of relationships that are consistently upheld is integral to ensuring the sustained performance of a business. In alignment with this, multiple studies affirm that a company's ability to cultivate high-quality relationships within its business activities fosters a continuous enhancement in business performance (Ghee et al., 2015; Mokhber, Gi, et al., 2017). The quality aspect of these relationships establishes trust among family members and safeguards the preservation of core values (Kiwia et al., 2019; Sonfield et al., 2014). As a result, we present the following hypothesis:

Hypothesis 3: Intergenerational Relationship Quality positively influences Business Performance.

Business Performance and Firm-Family Sustainability

Entrepreneurs are tasked with the challenge of developing resources to foster the creation of new products (Pistrui et al., 2001). Numerous studies suggest that entrepreneurial behaviors

tend to be passed on to the succeeding generation, emphasizing the significance of business growth in ensuring the sustainability of family businesses (Casillas et al., 2010; Mullens, 2018). This regeneration process highlights that the expansion of family businesses plays a pivotal role in guaranteeing their longevity (Olson et al., 2003). Enhanced business performance serves as a driving force for the sustainability and competitive advantage of family enterprises (Bernhard et al., 2020; Olson et al., 2003).

The performance indicator, namely business growth, manifests in the form of increased revenues, an expanded customer base, and extended market reach, which, in turn, has a lasting impact on business continuity for future generations (Martínez et al., 2013). The quality of relationships established within the succeeding generation emerges as a key catalyst for augmenting company performance and fortifying the sustainability of the business (Carrasco-Hernández et al., 2013). Business performance, as observed in several studies, significantly contributes to the future sustainability of the business (Chaimahawong et al., 2013; Mokhber, Gi, et al., 2017; Wahjono et al., 2014). Additionally, research indicates that business continuity serves as a testament to the success of the business that has been built and sustained from one generation to the next (Miller et al., 2003; Moreno-Gené et al., 2021; Nyalita, 2015). Hence, we propose the following hypothesis:

Hypothesis 4: Business Performance positively influences Firm-Family Sustainability

Building upon the literature review and the logically proposed hypotheses, Figure 1 presents the conceptual research model. The quality of intergenerational relationships is posited as a mediating variable that interconnects various aspects of entrepreneurial knowledge with knowledge sustainability.

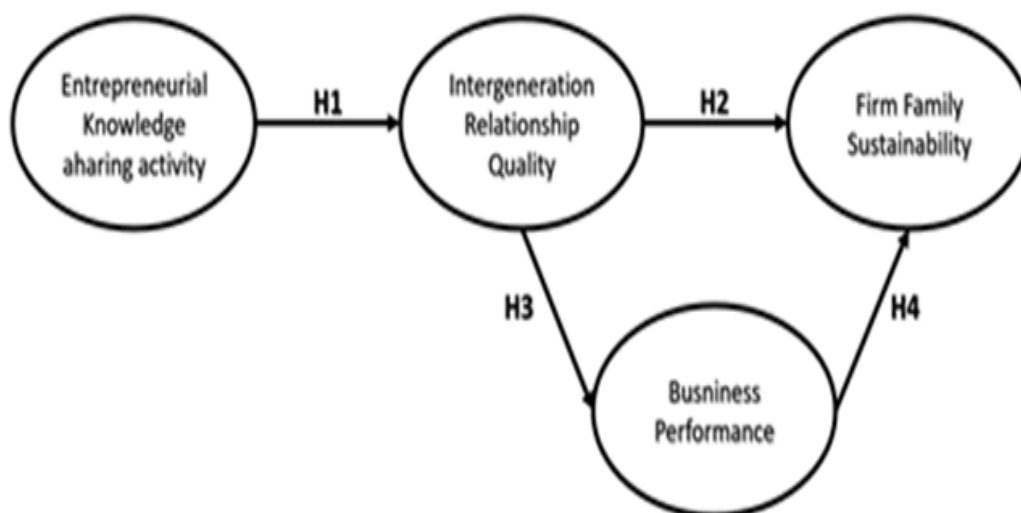

Figure 1: Structural model

METHODOLOGY

Business Performance and Firm-Family Sustainability

A family business was selected as the subject for our study to test the proposed model, driven by several considerations. Firstly, family businesses play a crucial role in fostering economic growth within a region. Such businesses are typically built upon shared values that prioritize business continuity. Moreover, our research aimed to scrutinize the sustainability of family firms. To ensure the robustness of our study, we gathered samples from various districts in Central Java, as this region is characterized by a significant dominance of family-owned companies, accounting for approximately 90% of business ownership. We employed purposive sampling techniques, with specific criteria such as businesses that have operated for more than one generation, and businesses located in the districts of Jepara, Apex, Solo, and Semarang, encompassing various industries such as batik, furniture, and culinary enterprises (Isstianto, 2017; Statistik, 2015). Data collection was conducted during November-December 2022, involving trained enumerators.

The primary instrument employed in this study was a 7-point Likert scale questionnaire. The questionnaire was pre-tested to enhance its effectiveness and credibility. We aimed to collect 250 samples to meet the requirements for data processing, aligning with the adequacy of the sample in structural equation modeling (SEM) (Hair et al., 2010). We utilized Amos 24 software for model analysis. The rationale behind adopting Structural Equation Model (SEM) is its ability to simultaneously examine causal relationships between variables and their indicators. It also facilitates the testing of partial mediation variables, enabling the derivation of an appropriate model (Hiong et al., 2020). Subsequent to testing, the final sample size was adjusted to 198 due to the identification of an outlier. The characteristics of the respondents are detailed in Table 1, derived from the results of our descriptive analysis.

Table 1: Demographic features

		F	F (%)			F	F (%)
Age	25-40 Year	120	60,6	Generation	KE 2	97	49
	41-60 Year	78	39,4		KE 3	66	33,3
					>3	35	17,7
Education	High School	139	70,2	Marketing	Domestik	147	74
	Undergraduate	55	27,8		Asia	34	17
	Post graduate	4	2		Eropa	17	9
Gender	famele	133	67,2	Business Sector	Batik	98	49%
	Male	65	32,8		Furniture	57	29%
					Kulinier	43	22%

Note: N = 198

Source : Authors' own

Development of Measures

Four indicators were employed to measure the Entrepreneurial Knowledge Sharing variable (Aklamanu et al., 2016; Yoo et al., 2007). Intergeneration Relationship Quality was assessed

using four indicators (Athanasopoulou, 2009; Vieira et al., 2008). Additionally, Business Performance and Family Business Sustainability variables were gauged through four indicators (Nordqvist et al., 2013; Poza, 2013). Detailed information about the specific items used for measurement can be found in Table 2.

Table 2: Measurement of validity and reliability of the construct.

Variable Indicators	Items scale	Reference	standardized loadings	Cronbach's alpha	CRI	CV-AVE
Entrepreneurial Knowledge Sharing Activity						
EKSA1	We always share knowledge and experience.	(Aklamanu et al., 2016; Yoo et al., 2007)	0.754	0.804	0.938	0.578
EKSA2	Provide motivation and values in business.		0.799			
EKSA4	The entrepreneurial experience becomes a succession capital for the next generation.		0.727			
Intergeneration Relationship Quality						
IRQ1	Relationship with my parents is positive	(Athanasopoulou, 2009; Vieira et al., 2008)	0.710	0.783	0.829	0.539
IRQ2	Relationship with my parents at work is professional		0.758			
IRQ3	I have a really open relationship with my parents		0.733			
Business Performance						
BF2	The company's profit increased compared to the previous year.	(Nordqvist et al., 2013; Poza, 2013)	0.757	0.762	0.825	0.524
BF3	Our company's customers increased from the previous year		0.688			
BF4	Our sales results increased compared to the previous year		0.725			
Sustainability Family Business						
FFB2	Harmony has been created between the family and the family business.	(Nordqvist et al., 2013; Poza, 2013)	0.788	0.805	0.839	0.582
FFB3	our family business is professionally designed		0.725			
FFB4	family business sustainability is built on cultural values		0.774			
Noted: *AVE: Convergent validity – average variance extracted; CR: Construct reliability index						

STATISTICAL ANALYSIS AND RESULTS

Confirmatory factor analysis was conducted to assess the validity and reliability of the indicators for each variable (Tabachnick et al., 2007). Convergent validity was evaluated with the criterion of average variance extracted (AVE) ≥ 0.5 . The AVE values for the variables were as follows: Entrepreneurial Knowledge Sharing Activity 0.578, Intergeneration Relationship Quality 0.539, Business Performance 0.524, and Firm-Family Sustainability 0.582. All indicators exhibited factor loadings above 0.60 (Bagozzi et al., 1988), and the construct reliability index exceeded 0.70 (Arbuckle et al., 2016).

Table 4 demonstrates a significant influence of Entrepreneurial Knowledge-Sharing Activity on Intergeneration Relationship Quality. The findings of this study are consistent with prior research that highlights how diverse entrepreneurial knowledge fosters the development of quality relationships across generations, subsequently impacting business sustainability (Birditt et al., 2012; Osmani et al., 2014). The study's results also reveal that the second generation of business actors constitutes 97 (49%), the third generation comprises 66 (33.3%), and more than three generations account for 35 (17.7%), as indicated in Table 1. Therefore, the improvement in the quality of intergenerational relationships positively contributes to enhanced performance and business sustainability (Martini, 2016).

Likewise, in alignment with Hypothesis H2, it was found that Intergeneration Relationship Quality significantly influences Business Performance. This aligns with previous research (Hacker & Dowling, 2012; Nordqvist & Melin, 2010; Pardo-del-Val, 2009), which emphasizes that the quality of relationships established between generations is a crucial variable in bridging the gap in understanding the interplay of entrepreneurial knowledge and the sustainability of family businesses.

Hypotheses 3 and 4 also yielded significant effects. Company performance positively affects business continuity, while the quality of relationships plays a substantial role in ensuring business continuity. Shared commitments and values rooted in family culture are pivotal in determining the sustainability of a family business. Therefore, emphasizing the quality of intergenerational relationships is integral to continued growth, as it is positively correlated with both business performance and sustainability (Birditt et al., 2012; Vieira et al., 2008).

Table 3: The structural coefficient of regression

Hypothesis			Standardized Estimate	Critical Ratio	P-Value	Result
H1: Intergeneration Relationship Quality	←	Entrepreneurial Knowledge sharing	.083	8.087	***	Supported
H2: Firm-Family Sustainability	←	Intergeneration Relationship Quality	.081	8.203	***	Supported
H3: Business Performance	←	Intergeneration Relationship Quality	.123	4.978	***	Supported
H4: Firm-Family Sustainability	←	Business Performnace	.127	2.573	0.010	Supported

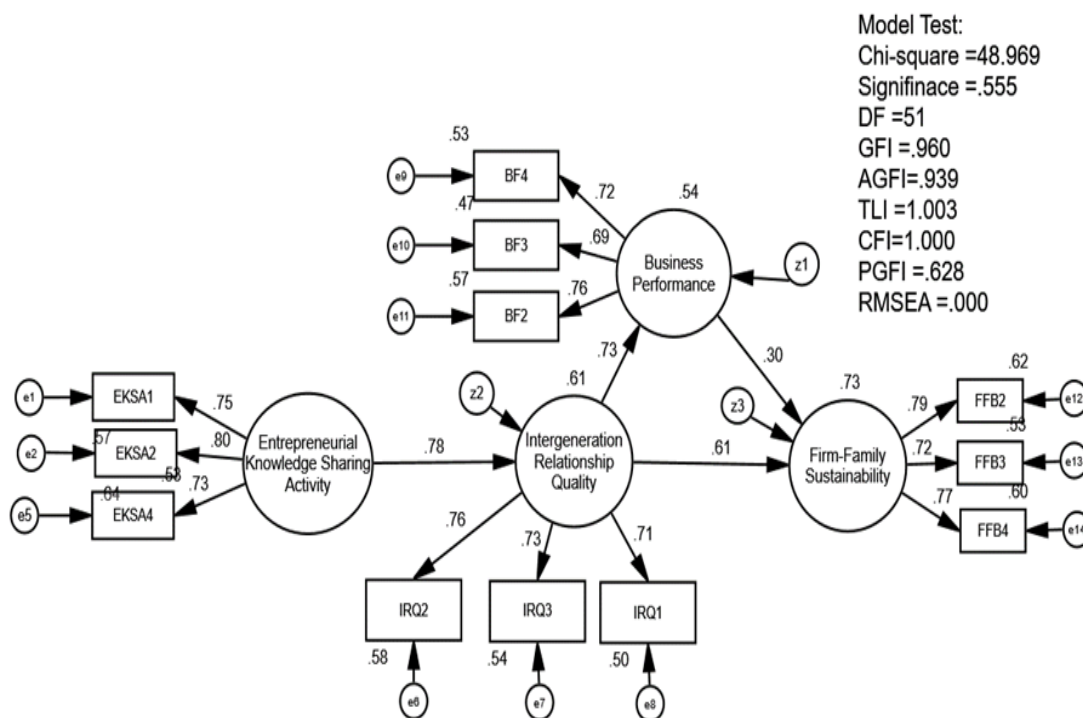

Figure 2: Intergeneration Relationship Quality and Firm Family Sustainability

Descriptive statistics and correlations are detailed in Tables 3 and 4. In Table 4, a noteworthy correlation is observed among Entrepreneurial Knowledge-Sharing Activity, Intergeneration Relationship Quality, Business Performance, and Family-Firm Sustainability

Table 4: Descriptive statistics

Variable	Mean	Standard Deviation	Min	Max	Sum
1. Entrepreneurial Knowledge-Sharing Activity	,18254	2,56851	11,00	22,67	3431,00
2. Intergeneration Relationship Quality	,15715	2,21132	11,33	23,00	3638,33
3. Business Performance	,14260	2,00658	14,00	22,00	3627,67
4. Family-Firm Sustainability	,14934	2,10146	11,00	23,33	3830,00

CONCLUSION

Previous studies (Asgarian, 2012; Matin et al., 2010) emphasize the importance of knowledge sharing in activities related to experiences of business success and the transmission of company-adopted values. Effective knowledge sharing is greatly influenced by cultural factors, motivation, and commitment (Abili et al., 2011; Dennis M. Garvis Shaker A. Zahra, 2017). Knowledge sharing's essence lies in the willingness of family members to impart their experiences, expertise, and information to other family members (Lin, 2007). Consequently, business actors with diverse entrepreneurial experiences and knowledge are more likely to

foster the development of quality relationships across generations. The quality of these relationships plays a pivotal role in ensuring business continuity. This finding aligns with research by Jehn & Bezrukova (2004), which underscores that a company's ability to foster a culture of knowledge sharing encourages family members to collaborate in problem-solving and idea generation.

Family businesses that can promote knowledge sharing among family members are better positioned to generate fresh ideas, enhance business productivity, and maintain harmonious relationships and a commitment to passing on family values. Productive activities ensure business continuity (Sundaram, 2019) while enabling members to learn and acquire new skills and knowledge (Bock et al., 2005; Chen et al., 2012).

The family businesses examined in this study have spanned more than three generations. It is imperative to preserve this continuity to uphold both sustainability and family values. The alignment and commitment to preserving family values create a conducive work environment. Knowledge sharing becomes a behavioral culture, facilitating the transfer of knowledge to assist family members. The company's dedication to establishing quality relationships with the next generation is paramount to perpetuating the values inherent in family businesses. The quality of intergenerational relationships also serves as a mediating factor between the sharing of entrepreneurial knowledge and business sustainability.

Future research should explore additional variables related to building business sustainability, such as intergenerational conflicts, with a more specific focus on a single business sector, such as the batik industry. Sustainability in the context of family businesses encompasses business growth, the perpetuation of entrepreneurial spirit across generations, and the cultivation of emotional bonds among family members in business management. The quality of intergenerational relationships positively influences business performance and sustainability (Ghee et al., 2015; Mokhber, Gi Gi, et al., 2017).

References

- 1) Aklamanu, A., Degbey, W. Y., & Tarba, S. Y. (2016). The role of HRM and social capital configuration for knowledge sharing in post-M&A integration: a framework for future empirical investigation. *The International Journal of Human Resource Management*, 27(22), 2790-2822.
- 2) Alderson, K. J. (2018). *Understanding the family business: Exploring the differences between family and nonfamily businesses*: Business Expert Press.
- 3) Allouche, J., Amann, B., Jaussaud, J., & Kurashina, T. (2008). The impact of family control on the performance and financial characteristics of family versus nonfamily businesses in Japan: A matched-pair investigation. *Family Business Review*, 21(4), 315-330.
- 4) Anderson, R. C., & Reeb, D. M. (2003). Founding-family ownership and firm performance: evidence from the S&P 500. *The journal of finance*, 58(3), 1301-1328.
- 5) Arbuckle, T. E., Liang, C. L., Morisset, A.-S., Fisher, M., Weiler, H., Cirtiu, C. M., . . . Fraser, W. D. (2016). Maternal and fetal exposure to cadmium, lead, manganese and mercury: the MIREC study. *Chemosphere*, 163, 270-282.

- 6) Aronoff, C. E., & Ward, J. L. (1995). Family-owned businesses: a thing of the past or a model for the future? *Family business review*, 8(2), 121-130.
- 7) Athanasopoulou, P. (2009). Relationship quality: a critical literature review and research agenda. *European Journal of Marketing*.
- 8) Bagozzi, R. P., & Yi, Y. (1988). On the evaluation of structural equation models. *Journal of the academy of marketing science*, 16(1), 74-94.
- 9) Bai, X. (2018). Development and validation of a multidimensional intergenerational relationship quality scale for aging Chinese parents. *The Gerontologist*, 58(6), e338-e348.
- 10) Barney, J. (2001). The resource-based view of the firm: Ten years after 1991. *Journal of Management*, 27(6), 625-641. doi: 10.1177/014920630102700601
- 11) Barros-Contreras, I., & Palma-Ruiz, J. M. (2020). Knowledge accumulation and its effects on organizational effectiveness in family firms *Intrapreneurship and Sustainable Human Capital* (pp. 155-167): Springer.
- 12) Barroso Martínez, A., Sanguino Galván, R., & Bañegil Palacios, T. (2013). Study of factors influencing knowledge transfer in family firms. *Intangible Capital*, 9(4), 1216-1238.
- 13) Bengtson, V., Giarrusso, R., Mabry, J. B., & Silverstein, M. (2002). Solidarity, conflict, and ambivalence: Complementary or competing perspectives on intergenerational relationships? *Journal of Marriage and the Family*, 568-576.
- 14) Bennedsen, M., & Nielsen, K. M. (2010). Incentive and entrenchment effects in European ownership. *Journal of Banking & Finance*, 34(9), 2212-2229.
- 15) Bernhard, F., Hiepler, M., & Engel, F.-X. (2020). Family business sustainability: the intergenerational transfer of social capital and network contacts *Sustainable Innovation* (pp. 101-132): Springer.
- 16) Berrone, P., Cruz, C., & Gomez-Mejia, L. R. (2012). Socioemotional wealth in family firms: Theoretical dimensions, assessment approaches, and agenda for future research. *Family business review*, 25(3), 258-279.
- 17) Birditt, K. S., Tighe, L. A., Fingerman, K. L., & Zarit, S. H. (2012). Intergenerational relationship quality across three generations. *J Gerontol B Psychol Sci Soc Sci*, 67(5), 627-638. doi: 10.1093/geronb/gbs050
- 18) Boyd, B., Royer, S., Pei, R., & Zhang, X. (2015). Knowledge transfer in family business successions: Implications of knowledge types and transaction atmospheres. *Journal of Family Business Management*.
- 19) Cabrera-Suárez, K., De Saá-Pérez, P., & García-Almeida, D. (2001). The succession process from a resource- and knowledge-based view of the family firm. *Family Business Review*, 14(1), 37-48.
- 20) Carlock, R. S. (2010). *When family businesses are best the parallel planning process for family harmony and business success*: Springer.
- 21) Carrasco-Hernández, A., & Jiménez-Jiménez, D. (2013). Can family firms innovate? Sharing internal knowledge from a social capital perspective. *Electronic Journal of Knowledge Management*, 11(1), 30.
- 22) Casillas, J. C., Moreno, A. M., & Barbero, J. L. (2010). A configurational approach of the relationship between entrepreneurial orientation and growth of family firms. *Family business review*, 23(1), 27-44.
- 23) Chaimahawong, V., & Sakulsriprasert, A. (2013). Family business succession and post succession performance: Evidence from Thai SMEs. *International Journal of Business and Management*, 8(2), 19.
- 24) Chenet, P., Dagger, T. S., & O'Sullivan, D. (2010). Service quality, trust, commitment and service differentiation in business relationships. *Journal of Services Marketing*, 24(5), 336-346.
- 25) Chrisman, J. J., Chua, J. H., & Sharma, P. (2005). Trends and directions in the development of a strategic management theory of the family firm. *Entrepreneurship Theory and Practice*, 29(5), 555-575.

- 26) Claessens, S., Djankov, S., & Lang, L. H. (2000). The separation of ownership and control in East Asian corporations. *Journal of financial Economics*, 58(1-2), 81-112.
- 27) Danes, S. M., Stafford, K., Haynes, G., & Amarapurkar, S. S. (2009). Family capital of family firms: Bridging human, social, and financial capital. *Family Business Review*, 22(3), 199-215.
- 28) Daspit, J. J., Chrisman, J. J., Sharma, P., Pearson, A. W., & Long, R. G. (2017). A strategic management perspective of the family firm: Past trends, new insights, and future directions. *Journal of Managerial Issues*, 6-29.
- 29) Fahed-Sreih, J. (2018). Conflict in family businesses *Conflict in Family Businesses* (pp. 53-78): Springer.
- 30) Family Firm Institute, I. (2013). *Family Enterprise: Understanding Families in Business and Families of Wealth, + Online Assessment Tool*: Wiley.
- 31) Fingerman, K. L., Pitzer, L., Lefkowitz, E. S., Birditt, K. S., & Mroczek, D. (2008). Ambivalent relationship qualities between adults and their parents: Implications for the well-being of both parties. *The Journals of Gerontology Series B: Psychological Sciences and Social Sciences*, 63(6), P362-P371.
- 32) Fingerman, K. L., Pitzer, L. M., Chan, W., Birditt, K., Franks, M. M., & Zarit, S. (2011). Who gets what and why? Help middle-aged adults provide to parents and grown children. *Journals of Gerontology Series B: Psychological Sciences and Social Sciences*, 66(1), 87-98.
- 33) Foss, N. J., Husted, K., & Michailova, S. (2010). Governing knowledge sharing in organizations: Levels of analysis, governance mechanisms, and research directions. *Journal of Management Studies*, 47(3), 455-482.
- 34) Geiger, D., & Schreyögg, G. (2012). Narratives in knowledge sharing: challenging validity. *Journal of Knowledge Management*.
- 35) Ghee, W. Y., Ibrahim, M. D., & Abdul-Halim, H. (2015). Family business succession planning: Unleashing the key factors of business performance. *Asian Academy of Management Journal*, 20(2).
- 36) Gomez-Mejia, L., Cruz, C., & Imperatore, C. (2014). Financial reporting and the protection of socioemotional wealth in family-controlled firms. *European Accounting Review*, 23(3), 387-402.
- 37) Gómez-Mejía, L. R., Haynes, K. T., Núñez-Nickel, M., Jacobson, K. J., & Moyano-Fuentes, J. (2007). Socioemotional wealth and business risks in family-controlled firms: Evidence from Spanish olive oil mills. *Administrative Science Quarterly*, 52(1), 106-137.
- 38) Hair, J. F., Black, W. C., Babin, B. J., & Anderson, R. E. (2010). *Multivariate Data Analysis* (Vol. Edisi 7): Prentice Hall.
- 39) Hnátek, M. (2015). Entrepreneurial thinking as a key factor of family business success. *Procedia-Social and Behavioral Sciences*, 181, 342-348.
- 40) Howorth, C., Rose, M., Hamilton, E., & Westhead, P. (2010). Family firm diversity and development: An introduction. *International Small Business Journal*, 28(5), 437-451.
- 41) Huang, M.-C., Chiu, Y.-P., & Lu, T.-C. (2013). Knowledge governance mechanisms and repatriate's knowledge sharing: the mediating roles of motivation and opportunity. *Journal of Knowledge Management*.
- 42) Huggins, R., Johnston, A., & Thompson, P. (2012). Network capital, social capital and knowledge flow: how the nature of inter-organizational networks impacts on innovation. *Industry and Innovation*, 19(3), 203-232.
- 43) Kandade, K., Samara, G., Parada, M. J., & Dawson, A. (2021). From family successors to successful business leaders: A qualitative study of how high-quality relationships develop in family businesses. *Journal of Family Business Strategy*, 12(2), 100334.
- 44) Kayser, G., & Wallau, F. (2002). Industrial family businesses in Germany—Situation and future. *Family business review*, 15(2), 111-115.

- 45) Kellermanns, F. W., Eddleston, K. A., Barnett, T., & Pearson, A. (2008). An exploratory study of family member characteristics and involvement: Effects on entrepreneurial behavior in the family firm. *Family business review*, 21(1), 1-14.
- 46) Kiwia, R. H., Bengesi, K. M., & Ndyetabula, D. W. (2019). Succession planning and performance of family-owned small and medium enterprises in Arusha City–Tanzania. *Journal of Family Business Management*.
- 47) Koentjoro, S., & Gunawan, S. (2020). Managing knowledge, dynamic capabilities, innovative performance, and creating sustainable competitive advantage in family companies: A case study of a family company in Indonesia. *Journal of Open Innovation: Technology, Market, and Complexity*, 6(3), 90.
- 48) Leach, P. (2011). *Family businesses: The essentials*: Profile Books.
- 49) Liao, H., Liu, D., & Loi, R. (2010). Looking at both sides of the social exchange coin: A social cognitive perspective on the joint effects of relationship quality and differentiation on creativity. *Academy of Management Journal*, 53(5), 1090-1109.
- 50) Liu, C., & Bai, X. (2021). *Well-being in Hong Kong ageing families: correlates of intergenerational relationship quality*. Paper presented at the Asian Journal of Gerontology and Geriatrics.
- 51) Lumpkin, G. T., Brigham, K. H., & Moss, T. W. (2010). Long-term orientation: Implications for the entrepreneurial orientation and performance of family businesses. *Entrepreneurship & regional development*, 22(3-4), 241-264.
- 52) Martínez, A. B., Galván, R. S., & Palacios, T. M. B. (2016). An empirical study about knowledge transfer, entrepreneurial orientation and performance in family firms. *European Journal of International Management*, 10(5), 534-557.
- 53) Martínez, A. B., Palacios, T. M. B., & Galván, R. S. (2013). Validation of a Measuring Instrument for the Relationship between Knowledge Transfer and Entrepreneurial Orientation in Family Firms. *Journal of Small Business Strategy*, 23(2), 1-14.
- 54) Memili, E., Fang, H., Chrisman, J. J., & De Massis, A. (2015). The impact of small-and medium-sized family firms on economic growth. *Small Business Economics*, 45, 771-785.
- 55) Miller, D., Steier, L., & Le Breton-Miller, I. (2003). Lost in time: Intergenerational succession, change, and failure in family business. *Journal of business venturing*, 18(4), 513-531.
- 56) Miroshnychenko, I., De Massis, A., Miller, D., & Barontini, R. (2021). Family business growth around the world. *Entrepreneurship Theory and Practice*, 45(4), 682-708.
- 57) Mokhber, M., Gi Gi, T., Abdul Rasid, S. Z., Vakilbashi, A., Mohd Zamil, N., & Woon Seng, Y. (2017). Succession planning and family business performance in SMEs. *Journal of Management Development*, 36(3), 330-347.
- 58) Mokhber, M., Gi, T. G., Rasid, S. Z. A., Vakilbashi, A., Zamil, N. M., & Seng, Y. W. (2017). Succession planning and family business performance in SMEs. *Journal of Management Development*.
- 59) Moreno-Gené, J., & Gallizo, J. L. (2021). Intergenerational Differences in Family Business Management and Their Influence on Business Profitability. *Sustainability*, 13(12), 6979.
- 60) Mullens, D. (2018). *Entrepreneurial orientation and sustainability initiatives in family firms*: emerald.com.
- 61) Murphy, L., & Lambrechts, F. (2015). Investigating the actual career decisions of the next generation: The impact of family business involvement. *Journal of Family Business Strategy*, 6(1), 33-44.
- 62) Nordqvist, M., & Melin, L. (2010). The promise of the strategy as practice perspective for family business strategy research. *Journal of Family Business Strategy*, 1(1), 15-25.

- 63) Nordqvist, M., Wennberg, K., & Hellerstedt, K. (2013). An entrepreneurial process perspective on succession in family firms. *Small Business Economics*, 40(4), 1087-1122.
- 64) Nyalita, A. M. (2015). *Succession planning, entrepreneurial orientation, business development services and performance of small and medium family businesses in Machakos county, Kenya*. University of Nairobi.
- 65) Olson, P. D., Zuiker, V. S., Danes, S. M., Stafford, K., Heck, R. K., & Duncan, K. A. (2003). The impact of the family and the business on family business sustainability. *Journal of Business Venturing*, 18(5), 639-666.
- 66) Pieper, T. M., Astrachan, J. H., & Manners, G. E. (2013). Conflict in family business: Common metaphors and suggestions for intervention. *Family Relations*, 62(3), 490-500.
- 67) Pillemer, K., & Suito, J. J. (2002). Explaining mothers' ambivalence toward their adult children. *Journal of Marriage and Family*, 64(3), 602-613.
- 68) Pistrui, D., Huang, W., Oksoy, D., Jing, Z., & Welsch, H. (2001). Entrepreneurship in China: Characteristics, attributes, and family forces shaping the emerging private sector. *Family business review*, 14(2), 141-152.
- 69) Poza, E. J. (2013). *Family business*: Cengage Learning.
- 70) Rustam, A. R., & Narsa, I. M. (2021). Good Corporate Governance: A Case Study of Family Business in Indonesia. *The Journal of Asian Finance, Economics and Business*, 8(5), 69-79.
- 71) Scuotto, V., Del Giudice, M., Bresciani, S., & Meissner, D. (2017). Knowledge-driven preferences in informal inbound open innovation modes. An explorative view on small to medium enterprises. *Journal of Knowledge Management*.
- 72) Sonfield, M. C., & Lussier, R. N. (2014). The Relationship between Managerial Characteristics and Succession Planning in Family Businesses: A Multinational Analysis. *American Journal of Entrepreneurship*, 7(1).
- 73) Songini, L., Gnan, L., & Malmi, T. (2013). The role and impact of accounting in family business. *Journal of Family Business Strategy*, 4(2), 71-83.
- 74) Suppiah, V., & Sandhu, M. S. (2011). Organisational culture's influence on tacit knowledge-sharing behaviour. *Journal of Knowledge Management*.
- 75) Tabachnick, B. G., Fidell, L. S., & Ullman, J. B. (2007). *Using multivariate statistics* (Vol. 5): pearson Boston, MA.
- 76) Tonggano, S., & Christiawan, Y. J. (2017). Pengaruh Kepemilikan keluarga terhadap profitabilitas perusahaan pada perusahaan menggunakan firm size, firm age dan sales growth sebagai variabel kontrol. *Business Accounting Review*, 5(2), 397-408.
- 77) Vieira, A. L., Winklhofer, H., & Ennew, C. T. (2008). Relationship Quality: a literature review and research agenda. *Journal of Customer Behaviour*, 7(4), 269-291. doi: 10.1362/147539208x386833
- 78) Wahjono, S. I., Idrus, S., & Nirbito, J. (2014). Succession planning as an economic education to improve family business performance in East Java Province of Indonesia. *Journal of Asian Scientific Research*, 4(11), 649-663.
- 79) Wang, S., & Noe, R. A. (2010). Knowledge sharing: A review and directions for future research. *Human Resource Management Review*, 20(2), 115-131. doi: 10.1016/j.hrmr.2009.10.001
- 80) Wang, Y., Watkins, D., Harris, N., & Spicer, K. (2004). The relationship between succession issues and business performance: Evidence from UK family SMEs. *International Journal of Entrepreneurial Behavior & Research*.

- 81) Wening, N., Haryono, T., & Harsono, M. (2016). Relationship between knowledge sharing to individual performance: The role of organizational culture and relationship quality as moderator in family business. *International Journal of Research in Business Management*, 4(1), 67-78.
- 82) Wong, K. Y., & Aspinwall, E. (2004). Characterizing knowledge management in the small business environment. *Journal of Knowledge Management*.
- 83) Yoo, Y., Lyytinen, K., & Heo, D. (2007). Closing the gap: towards a process model of post-merger knowledge sharing. *Information Systems Journal*, 17(4), 321-347.
- 84) Zachary, R. K. (2011). The importance of the family system in family business. *Journal of Family Business Management*.
- 85) Zheng, J., Qiao, H., Zhu, X., & Wang, S. (2020). Knowledge-driven business model innovation through the introduction of equity investment: evidence from China's primary market. *Journal of Knowledge Management*.